

Laser Scanner Manual



Table of Contents

| | |
|---|------------|
| Table of Contents | iii |
| Chapter 2: General Information | 1 |
| Notes and Signs | 1 |
| Chapter 3: Introduction | 2 |
| Differences between Scanners | 5 |
| Chapter 4: Equipment | 6 |
| Required additional equipment | 7 |
| Recommended additional equipment | 7 |
| Chapter 5: Safety Precautions | 8 |
| Intended Use | 8 |
| Improper Use | 8 |
| Operators | 8 |
| General Safety Information | 9 |
| Electrical Safety | 10 |
| Power Block Battery Safety Measures | 10 |
| Power Dock Battery Charger Safety Measures | 11 |
| Mechanical Safety | 11 |
| Transport | 12 |
| Storage | 13 |
| Servicing | 13 |
| Nameplate symbols | 14 |
| Chapter 6: Parts and Their Functions | 15 |
| Scanner Parts | 15 |
| Display Side | 15 |
| Battery Side | 16 |

| | |
|--|-----------|
| Front Side | 17 |
| Bottom Side | 17 |
| Power Dock Battery Charger | 18 |
| LED Behavior when Battery Charger is Connected to Power Source | 19 |
| Maintenance of Power Dock Battery Charger | 19 |
| Chapter 7: Getting Started | 20 |
| Charging the Battery | 20 |
| Charging the Battery in the FARO Laser Scanner | 20 |
| Charging the Battery with the Power Dock Battery Charger | 22 |
| Tips for Using the Battery | 24 |
| Setting up the FARO Laser Scanner | 25 |
| Setting up the Tripod | 25 |
| Mounting and Using the Quick Release | 27 |
| Prepare the Tripod | 27 |
| Prepare the Scanner | 28 |
| SD Card | 29 |
| Preparing an SD Card | 29 |
| File Structure of the SD Memory Card | 30 |
| Inserting the SD Card | 31 |
| Switching on the FARO Laser Scanner | 31 |
| Initial Scanner Settings | 32 |
| Setting the Interface Language | 32 |
| Setting the Date and Time | 33 |
| Setting the Date Format | 34 |
| Changing the Date and Time | 35 |
| Setting the Unit of Length and the Temperature Scale | 35 |
| Entering Scanner Information | 36 |
| Scanning | 37 |
| Setting the Scanning Parameters | 37 |
| Scanning Parameters Overview | 45 |
| Starting a Scan | 47 |
| Strong Scanner Inclination | 50 |
| LED Behavior | 50 |
| Data Security | 51 |
| Shutting Down the FARO Laser Scanner | 51 |
| Powering Off the FARO Laser Scanner | 51 |

| | |
|--|-----------|
| Chapter 8: Controller Software | 53 |
| General Elements | 53 |
| Status Bar | 53 |
| Navigation Bar | 54 |
| Frequently Used Buttons | 55 |
| Home Screen | 56 |
| Scan Parameters | 58 |
| Selected Profile | 59 |
| Resolution and Quality | 60 |
| Horizontal and Vertical Scan Range | 61 |
| Select Sensors | 62 |
| Scan with Color | 62 |
| Color Settings | 63 |
| Manage | 66 |
| Scan Projects and Clusters | 67 |
| Project Name | 69 |
| Parent Project | 69 |
| No Parent Project | 70 |
| Latitude [°] | 70 |
| Description of Project Button Icons | 72 |
| Scan Profiles | 73 |
| Operators | 77 |
| Sensors | 79 |
| Level the Scanner Using Inclinometer | 80 |
| General Settings | 85 |
| Status | 90 |
| WLAN Mode Scanner Settings | 91 |
| Access Point Mode Settings | 95 |
| Example Configuration of a Notebook with Microsoft Windows | 95 |
| Notebooks in Ad Hoc Mode | 96 |
| Remotely Accessing Scans on the SD Card | 97 |
| Scanner Details | 98 |
| On-Site Registration | 99 |
| Service | 101 |
| Automatic Backup | 104 |
| Manual Backup | 104 |
| Restore | 105 |
| Online Updates | 107 |
| Update via SD Card | 108 |

| | |
|--|------------|
| View Scans | 109 |
| Online Help and Notifications | 110 |
| Notifications | 110 |
| Help | 110 |
| Chapter 9: Special Scanning Modes | 112 |
| Scanner Control | 113 |
| On-Site Registration | 115 |
| On-Site Registration Setup | 116 |
| Map Page | 118 |
| List Page | 119 |
| Scan Details Page | 120 |
| On-Site Compensation | 122 |
| Preparing the Compensation Station | 122 |
| Connect Laser Scanner to Computer through Wireless LAN | 123 |
| On-Site Compensation Steps | 123 |
| Setup | 124 |
| Place target | 125 |
| Horizontal Alignment | 126 |
| Scan & Compensate | 127 |
| On-Site Compensation Best Practices | 128 |
| Troubleshooting | 129 |
| Scan Groups | 129 |
| Creating a Scan Group | 130 |
| Retaking Pictures | 131 |
| Chapter 10: Maintenance | 133 |
| Cleaning Instructions for Optics | 133 |
| What Is Needed | 134 |
| Cleaning Slightly Contaminated Optics | 135 |
| Dry Pre-Cleaning (Non-Contact Cleaning) | 135 |
| Wet Cleaning with Tissue and Isopropyl Alcohol as a Cleaning Fluid | 136 |
| Cleaning of Strongly Contaminated Optics | 142 |
| Dry Pre-Cleaning (Non-Contact Cleaning) | 142 |
| Wet Cleaning with Water or Diluted Mild Soap Solution | 143 |
| Chapter 11: Technical Data | 146 |
| General | 146 |

| | |
|---|------------|
| Laser (Optical Transmitter) | 146 |
| Data Handling and Control | 147 |
| Ranging Unit | 147 |
| Color Unit | 149 |
| Multi-Sensor | 149 |
| Interface Connection | 149 |
| Deflection Unit | 150 |
| Ambient Conditions | 150 |
| Notes | 150 |
| Scanner Dimensions | 151 |
| Scanner Mount Dimensions | 152 |
| Chapter 12: Error Messages | 153 |
| Chapter 13: Disposal | 155 |
| Chapter 14: Technical Support | 156 |
| Appendix A: Software License Agreement | 158 |
| Appendix B: Purchase Conditions | 160 |
| Appendix C: Industrial Service Policy | 166 |
| Appendix D: Industrial Products Service Policy | 171 |
| Appendix E: Certifications | 172 |
| FCC Notice | 172 |
| Industry Canada (IC): | 172 |
| CE Conformity | 174 |

Chapter 2: General Information

Notes and Signs

DANGER: DANGER denotes a hazard. It calls attention to an operating procedure or practice that, if not correctly performed or adhered to, will result in personal injury or death. Do not proceed beyond a DANGER notice until the indicated conditions are fully understood and met.

WARNING: WARNING denotes a hazard. It calls attention to an operating procedure or practice that, if not correctly performed or adhered to, could result in personal injury or death. Do not proceed beyond a WARNING notice until the indicated conditions are fully understood and met.

CAUTION: CAUTION denotes a hazard. It calls attention to an operating procedure or practice that, if not correctly performed or adhered to, could result in personal injury. Do not proceed beyond a CAUTION notice until the indicated conditions are fully understood and met.

NOTICE: NOTICE denotes a hazard. It calls attention to an operating procedure or practice that, if not correctly performed or adhered to, could result in damage to the product or loss of important data. Do not proceed beyond a NOTICE notice until the indicated conditions are fully understood and met.

NOTE: NOTE additional information that aids you in the use or understanding of the equipment or subject. They are not used when a WARNING or CAUTION is applicable. They are not safety related and may be placed either before or after the associated text.

Chapter 3: Introduction

The FARO Laser Scanner is a high-speed three-dimensional laser scanner for detailed measurement and documentation. The FARO Laser Scanner uses laser technology to produce exceedingly detailed three-dimensional images of complex environments and geometries in a few minutes. The resulting images are an assembly of millions of 3D measurement points.

Unless otherwise stated, the term FARO Laser Scanner is used for any of the FARO Laser Scanner FocusM 70, FocusS 70, FocusS 150 or 350, FocusS Plus 150 or 350 (and the automation versions of the Focus^S scanners).

The scanners are designed to scan objects at distances ranging between 0.6 meters and approximately 70, 150, and 350 meters.

The Focus^S series laser scanners offer a higher accuracy than the Focus^M series.



Figure 3-1 FARO Laser Scanner

The main features are:

- HYPERMODULATION™
- high accuracy
- high resolution
- high speed
- intuitive control through the built-in touchscreen display.
- easy mobility, due to its compact size, lightness, and the integrated quick charge battery.
 - High Dynamic Range (HDR) imaging method merges images captured with different exposure settings into one image with a greater dynamic range of luminosity.
 - photo-realistic 3D color scans, due to the integrated color camera.
 - integrated dual-axis compensator to automatically level the captured scan data.
 - integrated GPS sensor to determine the scanner position.
 - integrated compass and altimeter to give the scans orientation and height information.
 - WLAN to remotely control the scanner.

The FARO Laser Scanner works by sending an infrared laser beam into the center of a rotating mirror. The mirror deflects the laser beam on a vertical rotation around the environment being scanned; scattered light from surrounding objects is then reflected back into the scanner.

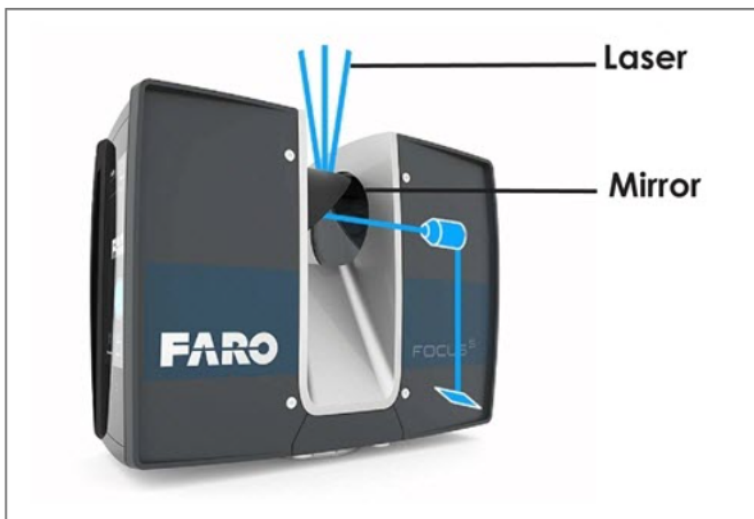

Figure 3-2 Laser Deflection

For distance measuring, FARO Laser Scanner uses phase-shift technology. This means that constant waves of infrared light of varying length are projected outward from the scanner. Upon contact with an object, the

light is reflected back to the scanner. The distance from the scanner to the object is accurately determined by measuring the phase shifts in the waves of the infrared light. HYPERMODULATION™ greatly enhances the signal-to-noise ratio of the modulated signal with the help of a special modulation technology. The x, y, z coordinates of each point are then calculated by using angle encoders, which measure the mirror rotation and the horizontal rotation of the FARO Laser Scanner. These angles are encoded simultaneously with the distance measurement. The scanner covers a 360° x 300° field of view.

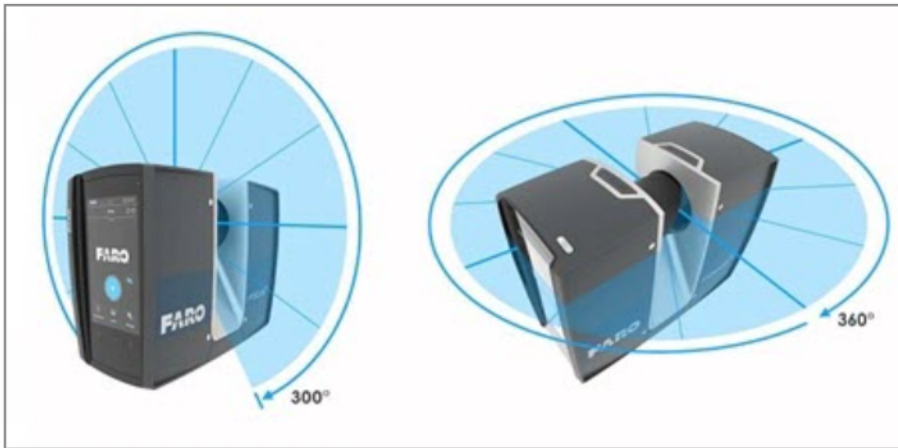

Figure 3-3 Vertical and Horizontal Rotation

Additionally, the FARO Laser Scanner determines the reflectivity of the captured surfaces by measuring the intensity of the received laser beam. Generally, bright surfaces reflect a greater portion of the emitted light than dark surfaces. This reflectivity is used to assign a corresponding value to each point.

The single point-measurements are repeated up to 976,000 times per second. The result is a point cloud; a three-dimensional data set of the scanner's environment (hereafter referred to as the laser scan, or simply scan). Depending on the selected resolution (points acquired per rotation), each point cloud consists of millions of scan points.

NOTE: The maximum single point measurement rate of the FocusM 70 is 488,000 times per second.

The laser scans are recorded on a removable SD card, enabling easy and secure transfer to SCENE, FARO's point cloud editing software.

This manual provides an introduction to the FARO Laser Scanner. Read the safety information in chapter [Safety Precautions on page 8](#) and the step-by-step guide in chapter [Getting Started on page 20](#) before using the FARO Laser Scanner.

You can also find various training and tutorial videos on the Internet at tutorial.faroeurope.com.

The scanner also has an on-screen help that can be accessed during operation by pressing the help button on the screen. [For more information, see "Online Help and Notifications" on page 110.](#)

A list of the potential fields-of-application of the FARO Laser Scanner can be found on the FARO web page www.faro.com.

Differences between Scanners

The features that this manual describes are not available on all FARO scanners. The table below summarizes the differences between the four models. Refer to the [technical specifications](#) for a complete description of the differences in range, accuracy, speed, etc.

| Feature | Focus ^M 70 | Focus ^S 70 | Focus ^S 150 or 350 | Focus ^S Plus 150 or 350 |
|-----------------------------------|-----------------------|-------------------------------------|---|--|
| Scanner base interface | not applicable | with version Focus ^S 70A | with version Focus ^S 150A / 350A | with version Focus ^S Plus 150A / 350A |
| Far distances scan profile | not applicable | not applicable | ✓ | ✓ |
| On-site compensation | not applicable | ✓ | ✓ | ✓ |
| On-site registration (with SCENE) | not applicable | ✓ | ✓ | ✓ |
| Accessory bay | not applicable | ✓ | ✓ | ✓ |
| Inverse mounting | ✓ | ✓ | ✓ | ✓ |
| Scanning speed (points / second) | up to 0.5 million | up to 1 million | up to 1 million | up to 2 million |

Chapter 4: Equipment

The FARO Laser Scanner is shipped with the following standard equipment:



- ❶ Scanner transport and carrying case
- ❷ Laser scanner. An SD card is already inserted in the scanner.
- ❸ Power supply unit
- ❹ Power Block battery (ACCS-PWR-0014)
- ❺ Quick Release
- ❻ Mirror cleaning liquid for optics

- 7 SD card reader
- 8 Power Dock battery charger
- 9 Quick Start Guide, situated in the case lid
- 10 AC power cable
- 11 Status Indicator (Not pictured. Only included with Focus^S Plus scanners.)

Required additional equipment

FARO-recommended tripod (FARO order number ACCSS8032)

Recommended additional equipment

- Spare battery
- Status Indicator
- Thermal Cover

NOTE: Keep all packing materials, as you may need them later.

NOTE: The SD memory card, a charged Power Block battery, and a tripod are the minimum required equipment for carrying out a scanning project.

Chapter 5: Safety Precautions

Read this user manual carefully and completely. Refer to it before using the product. Pay careful attention to all warnings, and follow the instructions step-by-step.

Intended Use

Use the product under the operating conditions and limitations described in this user manual.

Improper Use

Improper use means using the product other than described in this user manual, or under operating conditions that differ from those described herein.

Improper use of the product can impair the protection provided by the product, and product damage or serious personal injury can ensue.

Operators

In the interests of safety, the laser scanner and its accessories should only be used by suitably-trained and knowledgeable operators, after they have read and understood this manual, and carefully considered all potential hazards involved.

We recommend that operators participate in trainings offered by FARO.

General Safety Information

CAUTION:

- Do not open the housing. Opening the housing can result in serious personal injury or damage to the product, which will affect the product's warranty.
- Do not use parts not supplied or recommended by FARO.
- Only replacement parts authorized by FARO may be used, and in accordance with the instructions provided by FARO.
- Do not expose the FARO Laser Scanner and its accessories to **extreme temperatures**. The ambient temperature must not be lower or higher than given in the specifications. Do not use the FARO Laser Scanner near heat sources, such as radiators, heat registers, or other heat-producing products (including amplifiers).
- Do not **immerse** the FARO Laser Scanner and its accessories in **water**. Liquid inside the product enclosure can lead to damage, fire, or electric shocks.
- Properly dispose of the product and batteries in accordance to the local and national regulations. For more information, see [Disposal on page 155](#).
- Do not use the FARO Laser Scanner and its accessories in an **explosive environment**. Do not operate the instrument in the presence of flammable gases or fumes. Operation of any electrical instrument in such an environment constitutes a safety hazard.
- Do not use the FARO Laser Scanner in the vicinity of strong **magnetic or electrical fields**.

- Before operating the FARO Laser Scanner and its accessories in **hazardous areas**, contact the local safety authorities and safety experts.
- For **outdoor use**, use the Power Block battery as the power supply, ensuring that the device is protected from rain or spray water. Use the scanner in a non-condensing environment.
- When the product is transferred from a cold to a significantly-warmer environment, water may condense on some elements inside the scanner. To avoid this, place the scanner in an airtight plastic bag before transfer. This allows the condensation to form on the bag rather than inside the scanner. If you cannot pack the scanner in an airtight manner, wait until observable **condensation water** evaporates from the scanner before switching the FARO Laser Scanner on.

DANGER: Do not operate the scanner while the external power supply is plugged in. The power cable might damage the turning scanner.

Electrical Safety

WARNING: Do not open the housing.

Dangerously high voltages are present inside the enclosure. Only qualified service personnel should open the housing. Never push objects of any kind into this product through openings, as they may touch dangerous voltage points or cause short circuits. This could result in a fire, electric shock, or damage to the product.

- This product should be operated only from the power source or a battery supplied or recommended by FARO. Ensure that the specifications of the AC converter are met. If you do not know the power-line voltage in your area, consult your local power company.
- To avoid electrical shock, use the power-supply unit in dry indoor environments only.

Power Block Battery Safety Measures

These safety measures must be followed, when working with the Power Block battery:

- Only use the charger recommended by FARO to charge the battery.
- Do not charge or discharge damaged batteries.
- Do not charge the battery in the FARO Laser Scanner while it is stored in the transport case.
- Do not use wet or dirty batteries in the FARO Laser Scanner or with the charger.
- Charge between 0°C (32°F) and 40°C (104°F) environmental temperature. Recommended charging temperatures: 10°C (50°F) to 30°C (86°F).
- Discharge between -20°C (-4°F) and 60°C (140°F) environmental temperature. Recommended operating temperatures: 5°C (41°F) to 40°C (104°F).
- Insert or remove batteries from the laser scanner in dry, dust-free environments only.
- When the FARO Laser Scanner is not in use for long periods of time, remove the battery.
- Store the battery only when it is charged (at least 60% charge state). We recommend charging the battery once a year while it is in long-term storage.
- Storage temperatures are -20°C (-4°F) to 45°C (113°F). Storage humidity range is 0% to 80%. Store in a well-ventilated area. Do not store with metal objects. A short circuit can cause a fire.

- Do not bring metal objects into contact with the batteries' terminals. The terminals may short circuit and generate heat.
- Do not immerse batteries into water or fire (danger of explosion).
- Dispose of batteries in accordance with environmental regulations. Contact your local waste disposal management authority for guidelines concerning lithium ion batteries.

Power Dock Battery Charger Safety Measures

These safety measures must be followed, when working with the FARO Power Dock battery charger:

- Do not charge any batteries other than the FARO Power Block batteries in the FARO Power Dock charger.
- Regularly check the plug, cord, and charger. In case of damage, contact the FARO Customer Service.
- Do not bring metal objects or fluids into contact with the charger terminals. The terminals may short circuit and generate heat.
- To avoid electrical shock, use the charger and the power supply unit in dry indoor environments only.
- The charger should be kept in a dry room, out of the reach of children and pets.

NOTICE: Do not leave the battery in the Power Dock when it is not being charged, as this can result in a deep discharge state from which the battery cannot be recharged.

DANGER: Do not operate the charger in an environment allowing exposure to moisture, combustible fluids, or gases. There is a danger of explosion.

Mechanical Safety

WARNING: Rotating Mirror

The mirror unit rotates with high speed while scanning and for a short period after the scan. While the mirror is rotating keep distance to the product and do not touch the rotating mirror unit with your hands, fingers or any objects at the risk of personal injury and damage to the FARO Laser Scanner.

CAUTION: General Use

The FARO Laser Scanner may only be used when set on a flat and stable surface. Injuries may result if the FARO Laser Scanner overturns. Only use equipment recommended by FARO, and follow the setup instructions in this manual or the equipment manufacturer's manual.

Do Not Open the Housing

Opening the housing can cause serious personal injury and damage to the product.

NOTICE:

Cart Usage

If using a cart, move the setup with special care. Never move the cart by pulling the power cables. Pushing or pulling the cart with too much force, sudden stops, or on an uneven surface can cause disturbances of the FARO Laser Scanner's normal functioning.

Rotating Scanner

The FARO Laser Scanner rotates clockwise up to 360° when performing a scan. Ensure that the FARO Laser Scanner's scanner head can rotate freely and will not hit any objects during the scan.

Replacement Parts

Only **replacement parts** authorized by FARO can be used according to the instructions obtained from FARO. Do not use **parts** not supplied or recommended by FARO.

Transport

The following precautions must be taken when transporting the laser scanner equipment:

- The laser scanner must be turned off during transportation or shipping.
- The laser scanner must be in a transport case.
- Remove the battery from the laser scanner before shipping.
- When carrying the laser scanner, be careful not to drop it. Strong impact can damage the laser scanner, and render it incapable of proper operation.
- Carry the laser scanner separately from its equipment or, for optimal protection, use the original transport case.
- When shipping and transporting the laser scanner by rail, sea, air, or road, use its original transport case and a suitable outer cardboard box for optimal protection against shock and vibration.

- The FARO batteries are lithium-ion batteries and are thus classified as *dangerous goods*. When transporting or shipping the FARO batteries, ensure that you observe all applicable local and international rules and regulations. For further information, contact your local carrier before transportation or shipping.
- For lithium-ion batteries with less than 100 Wh energy content, an exemption is provided that allows you to carry such a battery without further paperwork. The maximum battery energy a single person can carry is 200 Wh.

NOTE: Ensure that the total energy content of all batteries that any individual person carries is less than 200 Wh, and that no single battery has more than 100 Wh energy content. Please review currently applicable national and international regulations for transport of Li-On batteries and also verify with you airline or freight company in advance.

Storage

Prior to storing the laser scanner for prolonged periods:

- remove the battery.
- pack the scanner and the battery in its shipping case to protect it from environmental hazards, dust, and dirt.
- store all components in an environment where:
 - the humidity level is low;
 - the temperature is relatively stable;
 - they are not be subjected to extreme temperatures, environmental conditions, or heavy vibrations.

Servicing

Servicing and repair must only be done by qualified service personnel authorized by FARO. Unplug the product from the power outlet and remove the battery. Request servicing, then deliver it to qualified service personnel under the following conditions, if:

- the power-supply cord or plug is damaged.
- the product has been exposed to rain, water, or other liquids.
- the product has been dropped or damaged in any way.

- objects have fallen onto the product.
- the product does not operate normally when following the operating instructions.
- the product exhibits a distinct change in performance.
- the required service and calibration date is reached.

Nameplate symbols



Indicates conformity with health, safety, and environmental protection standards for products sold within the European Economic Area.



Indicates that the product should not be discarded as unsorted waste but must be sent to separate collection facilities for recovery and recycling.



Indicates that the battery should be recycled in an environmentally suitable way.



Indicates that the battery should neither be incinerated nor set on fire.



Indicates that documentation is provided and required to use the product.



Indicates that there are no user serviceable parts inside the housing.



The nameplate on your FARO device may contain this symbol. It indicates that FARO has provided important information in the user manual regarding intended use and safety. Read this information before using the device.



Indicates that the product contains components with the Recognized Component Mark, which is a type of quality mark issued by Underwriters Laboratories (UL).



Indicates that the device is for indoor use only.

Chapter 6: Parts and Their Functions

Scanner Parts

Display Side



Figure 6-1 Display side of the FARO Laser Scanner

1 Power On/Off button - Press to turn on the FARO Laser Scanner. If the scanner is on and running, press again to turn it off. Pressing and holding for more than 3 seconds switches the FARO Laser Scanner off without shutting it down. Use only in exceptional cases, such as if the shut-down mechanism does not work or the FARO Laser Scanner is non-responsive.

2 Touch-screen display

3 Accessory bay 1

4 Accessory bay 2

NOTE: Ensure that the contacts in the accessory bay are clean before using. If not, clean with a cotton swab soaked in isopropyl alcohol.

The accessory bays are not available on all scanner models. See [Introduction on page 2](#). For details about the electrical interfaces of FARO Laser Scanner, FocusS 70, Focus^S (150 and 350), and Focus^S Plus (150 and 350) check the related Automation Interface Manual.

Battery Side

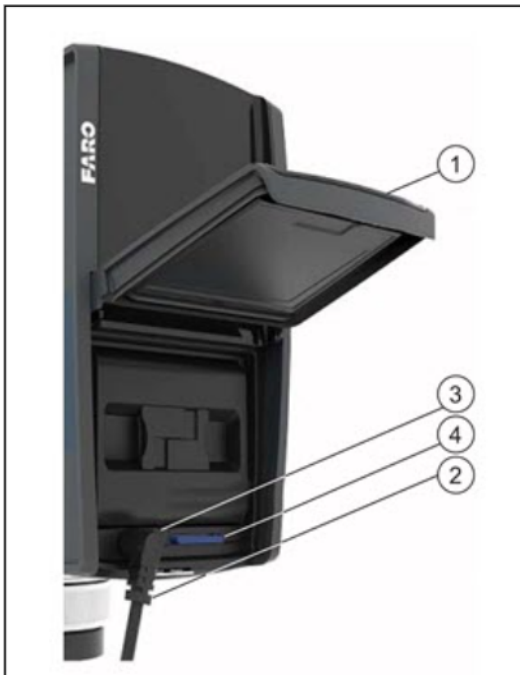

Figure 6-2 Battery Side of the FARO Laser Scanner

- ① Battery compartment cover
- ② Socket to plug an external power supply
- ③ LED showing battery status
- ④ SD card slot

Front Side



Figure 6-3 Front View of the FARO Laser Scanner

- ❶ **Scanner mirror** - For safety and cleaning instructions, see [Mechanical Safety](#) on page 11 and [Cleaning Instructions for Optics](#) on page 133.
- ❷ **Scanner mount**
- ❸ **Reference area** - Used for self-referencing the distance measurements while scanning.

Bottom Side

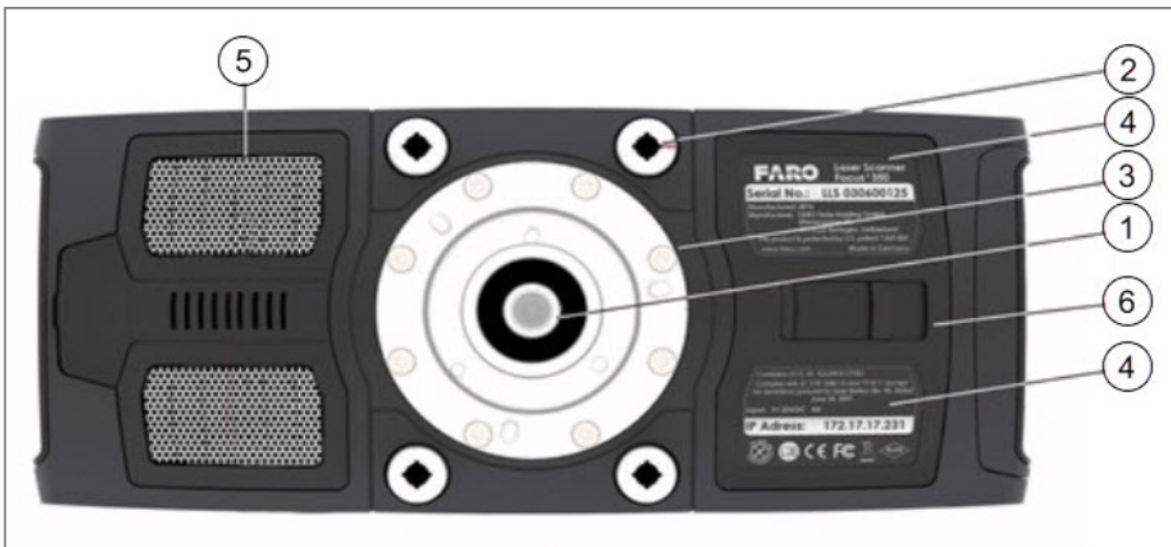

Figure 6-4 Bottom View of the FARO Laser Scanner

- ❶ **3/8" screw thread** - To mount the scanner to standard photo tripods.

- ② **M5 screw threads** - To mount the scanner to customer specific fixtures.
- ③ **Cover of the scanner base interface** - For automated applications. Remove to access the FARO Laser Scanner's automation interface. For more information, read the FARO Laser Scanner automation interface manual. Cover the automation interface, if it is not needed or not in-use.

NOTE: The scanner base interface is not available on all scanner models. See [Introduction on page 2](#).

- ④ **Type label**
- ⑤ **Cooling fan openings** - Keep these openings uncovered to ensure proper cooling of the scanner.
- ⑥ **Battery compartment cover release mechanism**

Power Dock Battery Charger

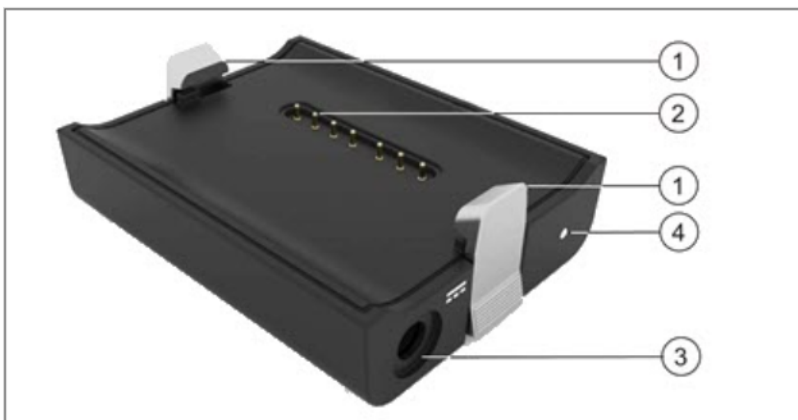

Figure 6-5 Power Dock Battery Charger

- ① **Safety clamps** - To insert the battery, pull downwards.
- ② **Connectors**
- ③ **Power socket**
- ④ **Power LED** - for LED specifications, see [LED Behavior when Battery Charger is Connected to Power Source on the next page](#).

Power Dock Battery Charger Technical data:

| | |
|------------------------|--|
| Rating voltage: | 19 V  |
| Maximum power: | 75 W |
| Operating temperature: | 0 °C to 40 °C |
| Humidity: | Non-condensing |
| Altitude: | up to 2000 m |
| Environment: | indoor (pollution degree 2) |

LED Behavior when Battery Charger is Connected to Power Source

When the battery charger is connected to the power source, its LED displays the charging state as described in the table below. There are two different power docks, named ACCSS8002 and ACCS-PWR-0013. The LED of the later one displays the same status as the scanner LED.

LED Behavior for Battery Charger ACCSS8002 rev 03

| Color | State |
|-----------------|--|
| cyan | Battery charging; charged above 90% (charging done). |
| orange | Battery charging. |
| orange blinking | Battery charging, charged less than 10%. |
| red | Unknown power source. Battery and AC adapter are not detected. |
| red blinking | Battery mostly discharged. |

LED Behavior¹ for Battery Charger ACCS-PWR-0013

| Color | State |
|-----------------|---------------------------------------|
| violet blinking | Battery charging. Charge at < 5% |
| red blinking | Battery charging. Charge at 5% - 15% |
| orange blinking | Battery charging. Charge at 5% - 25% |
| yellow blinking | Battery charging. Charge at 25% - 95% |
| green blinking | Battery charging. Charge at >95% |
| green | (full charged) ~100% |
| white | no battery |
| cyan blinking | error |

Maintenance of Power Dock Battery Charger

The Power Dock Battery Charger does not require much maintenance. If the charger becomes dirty or dusty, clean it with a soft dry cloth. If necessary, dampen the cloth with isopropyl alcohol. Always unplug the Power Dock Battery Charger and remove the battery before cleaning with alcohol.

¹LED is turned off after circa 15 seconds if not connected to power supply.

Chapter 7: Getting Started

This chapter provides preliminary steps and basic FARO Laser Scanner operation instructions, as well as guiding you step-by-step from setting up the FARO Laser Scanner to recording your first scan.

Charging the Battery

The Power Block battery can be charged in the FARO Laser Scanner or in the FARO Power Dock battery charger. Carefully read the safety instructions described in [Power Block Battery Safety Measures on page 10](#) and [Power Dock Battery Charger Safety Measures on page 11](#) before using them.

As a safety precaution, new batteries are shipped with a charge of less than 30%. New batteries must be completely charged before first use. We recommend fully charging the battery before each use. Keep a spare battery, if necessary, during your scan project.

DANGER: Danger of explosion or fire

Do not immerse batteries in water or fire.

Do not bring metal objects into contact with the battery terminals. The terminals may short circuit and over-heat.

DANGER: Danger of fire or electric shocks

Ensure that the devices are protected from rain or spraying water.

The power-supply unit and the Power Dock battery charger are not intended for outdoor use.

NOTICE: Do not leave the battery in the Power Dock when it is not being charged, as this can result in a deep discharge state from which the battery cannot be recharged.

The power-supply unit can be used in various countries. It is compatible with a 100 V AC to 240 V AC 50/60 Hz power source. Use a voltage adapter, if necessary.

Charging the Battery in the FARO Laser Scanner

1. Open the scanner's battery compartment cover.
2. Turn the battery so that its type label is directed upwards.

3. Point the battery contacts toward the scanner.
4. Push the battery straight in, sliding it downward into the battery compartment until the fastener clicks into position.



Figure 7-1 FARO Laser Scanner with Battery

5. Connect the cable of the power-supply unit to the power socket of the FARO Laser Scanner. If you use force while inserting the plug in a wrong direction, the plug and the FARO Laser Scanner can be damaged.
6. Connect the AC power cable to the power-supply unit and a power outlet. Check the input voltage on the type label before connecting.
7. If the FARO Laser Scanner is turned off, the scanner LEDs start blinking blue while charging. The LEDs stop blinking and illuminate a constant blue, when the battery is fully charged.
8. If the FARO Laser Scanner is turned on, check the battery's charging state in the scanner's user interface under [Frequently Used Buttons on page 55](#) > [Manage on page 66](#) > [General Settings on page 85](#) > [Power Management on page 87](#). [Power Management on page 87](#)

9. When charging is finished, remove the power-supply unit's cable. Close the battery compartment cover.



Figure 7-2 Power Supply connected to FARO Laser Scanner

DANGER: Do not operate the scanner while the external power-supply is plugged in, because the power cable might damage the turning scanner.

The FARO Laser Scanner does not need to be switched on to charge the battery.

NOTE: Remove FARO Laser Scanner from the transport case before connecting the power-supply to the scanner.

Before prolonged storage, remove the power-supply unit and the battery.

Charging the Battery with the Power Dock Battery Charger

NOTICE: Do not leave the battery in the Power Dock when it is not being charged, as this can result in a deep discharge state from which the battery cannot be recharged.

1. Connect the power-supply unit's cable to the power socket of the FARO Power Dock battery charger. If you use force while inserting the plug in a wrong direction, the plug and the Power Dock battery charger can be damaged.

CAUTION: Place the FARO Power Dock battery charger on a flat, non-slip surface. Ensure that the cable is positioned, so that it cannot accidentally be pulled by passing objects.



Figure 7-3 Power Dock battery charger with connected power cable

2. Connect the AC power cable to the power-supply unit and a power outlet. Check the input voltage on the type label before connecting.
3. The LED of the Power Dock battery charger illuminates blue for ACCSS8002 and white for ACCS-PWR-0013, when power is correctly connected
4. Place the battery on top of the Power Dock battery charger. Ensure that the battery terminals are aligned correctly with the pins of the charger. Snap the battery into place.

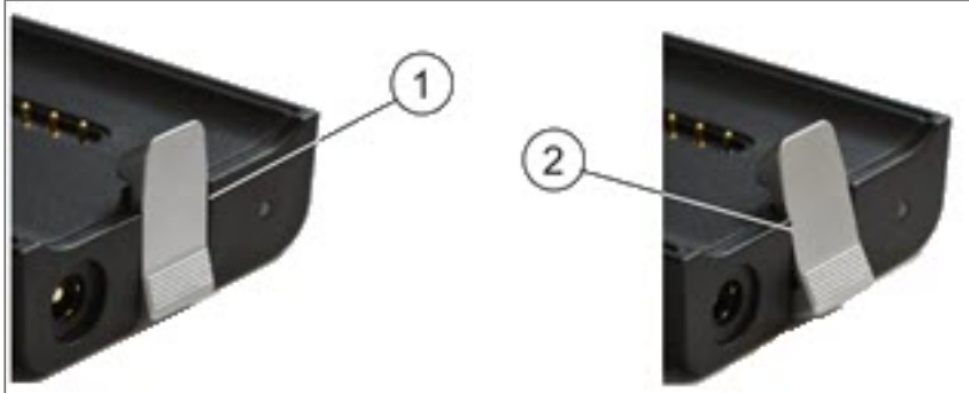

Figure 7-4 Placing the battery on the Power Dock battery charger

5. Charging starts automatically; the LED blinks and illuminates according to the current charging state of the battery. See [Power Dock Battery Charger](#) on page 18

After charging, carefully press the charger interlock mechanism and remove the battery.

NOTICE: Check the Power Dock for damage before use, being sure to check that the safety clamps have not been damaged, which can occur if the Power Dock falls while holding a Power Block:



- ❶ **Undamaged safety clamp** - Note the *vertical* position.
- ❷ **Damaged safety clamp** - Note the *slanted* position.

CAUTION: Do not use a damaged Power Dock. Doing so may damage the Power Block.

Tips for Using the Battery

- Charge the battery the day of use, or the day before. An unused, charged battery gradually loses its charge.
- If the battery empties quickly after being fully-charged, replace it with a new one.
- For optimal battery performance, an ambient temperature of 0°C (32°F) to 40°C (104°F) is recommended. In colder or warmer locations, battery performance and operation time may temporarily decrease and charge time may increase. If the battery temperature is too high, it may not charge at all until the battery cools down.

Setting up the FARO Laser Scanner

WARNING: Danger of injuries, especially to children or kneeling persons

- Injuries may result, if the FARO Laser Scanner overturns.
 - The FARO Laser Scanner may only be used on a flat, stable surface.
 - If using a cart, move the setup with special care. Never move the cart by pulling at the power cables. Pushing or pulling the cart with too much force, sudden stops, or over an uneven surface can upset of the FARO Laser Scanner.
 - In windy conditions, use sandbags to stabilize each foot of the tripod. You can also place a weight on the ground under the tripod, then stretch a rope or shock cord between the tripod's center hook and the weight.
-

Setting up the Tripod

For optimal performance, the base on which the scanner rests must be *absolutely* motionless. Any vibration or oscillation in the tripod or the ground on which the tripod stands can reduce the accuracy of the scan, and can lead to fringed or ghost lines, as shown below:

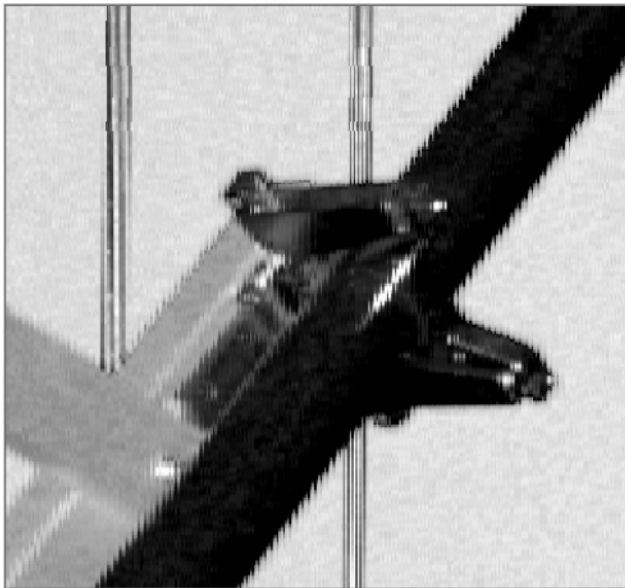

Figure 7-5 Sample scan result due to scanner vibration during data acquisition

Use a high-quality tripod. FARO recommends the GITZO ACCSS8032, available only from your FARO sales representative.

CAUTION: When adjusting the height of the tripod, assure that the scanner is NOT mounted. During leg adjustment, the tripod may become temporarily unstable, and could tip over, causing damage to the scanner.

While Working with the Laser Scanner

- Due to long recording times and high data-quality requirements, you must assure that the tripod is as stable as possible.
- Because a laser scanner moves during operation, the tripod must always be as rigid as possible.

To Achieve Stability and Rigidity

- Extend the tripod as little as possible. Less height means more accuracy.
- Extend the thicker segments of the legs before the thinner.
- You can extend a leg segment partially, if necessary, to achieve a specific height, but do not partially extend several segments of the same leg.
- The tripod has four leg segments, pull-out the first three fully, leaving the fourth one inserted. This results in a working height of approx. 148 cm, which allows an ergonomic operation of the scanner. Only pull-out the smallest leg segments when you need a higher tripod height.
- The tripod is equipped with large, adjustable rubber feet. Each time you move the tripod, ensure that the feet are correctly resting on the ground. If you need to place the tripod on unstable ground (e.g., grass, gravel, mud), use the supplied spikes instead of the rubber feet. Press the spikes individually into the ground until they reach a stable, load-bearing layer.
- After you set the tripod on the ground, check the leg latches. If any latches are loose, spread the legs slightly until the latches cannot be wiggled. This ensures that the tripod is firmly planted on the ground, and unlikely to shake or vibrate during scanning.
- The use of the center column significantly reduces the rigidity of the tripod. We recommend that you avoid using the center column. If you can't reach the tripod height needed in any other way, keep the extended length of the center column as short as possible. A better alternative is to move the tripod to a different, higher position. Use the center column only as a last resort. If you frequently need higher working heights, we recommend using a larger tripod.
- For scans close to the ground, slide all leg segments into each other before setting the leg angle to flat. The rubber feet have a recess that helps to achieve full-surface contact, even with a flat leg angle. To do this, turn the feet individually by hand.

- Ensure that the twist-lock sleeves for leg length adjustment, the central wing nut of the tripod shoulder, and the tripod head are always tightly screwed together.
- To achieve a better grip on hard surfaces, slightly tension the tripod legs before starting a scan. Tension the legs by holding two of the three tripod legs as close to the ground as possible with your hands, pulling them slightly apart from each other and away from the third leg, then pressing them into the ground.
- Under windy conditions, use sandbags to stabilize each foot of the tripod. You can also stretch a rope or shock cord between the tripod's center hook and a weight, switchable magnetic base, or existing anchor point.

Mounting and Using the Quick Release

The quick release enables you to quickly and safely attach and remove the scanner from the tripod. The quick release consists of these parts:

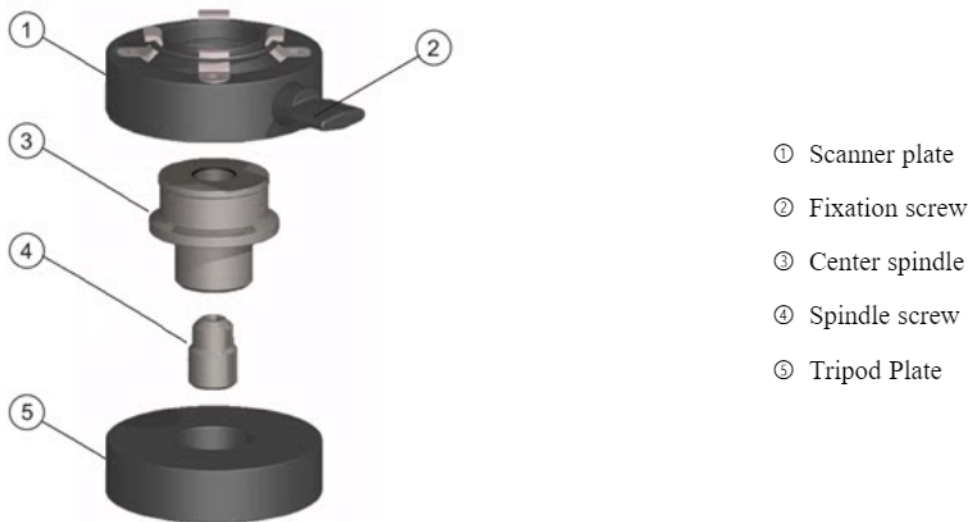

Figure 7-6 Quick release parts

Mounting the Quick Release

Prepare the Tripod

1. Extend the tripod legs and place the tripod on a stable surface at a convenient height. Ensure that all legs of the tripod are secure.

2. Your tripod might be equipped with one or more set screws in the platform. Ensure that the set screws are recessed below the platform. They must not stick up out of the surface.
3. Place the tripod plate over the center screw of the tripod.
4. Ensure that the spindle screw is firmly screwed into the narrow side of the center spindle.
5. Screw the center spindle firmly onto the tripod.

Prepare the Scanner

1. Place the scanner upside down on a stable, flat surface. Protect the mirror from dirt, dust, or falling objects.
2. Place the scanner plate onto the base of the scanner. Ensure that it slides into the circular depression surrounding the center thread.
3. Use a 4 mm hex key to tighten the four screws, so that the scanner plate is firmly attached to the scanner.
4. Extend the tripod legs and place the tripod on a stable surface at a convenient height. Ensure that all legs of the tripod are secure.

Use the Quick Release

1. Ensure that the tripod is level and the tripod plate is firmly attached to the tripod. Tighten manually, if necessary.
2. Ensure that the fixation screw in the scanner plate is unscrewed, so that it won't block the scanner plate from sliding over the center spindle.
3. Holding the scanner from both sides, slide the scanner plate over the center spindle.
4. Manually tighten the fixation screw until the scanner plate is firmly attached to the center spindle.

You can now use the scanner. To remove the scanner, loosen the fixation screw and lift the scanner from the center spindle.

SD Card

Preparing an SD Card

The FARO Laser Scanner stores the recorded scans on a removable SD card. This memory card can also be used to create backups of the scanner settings, to import scanner settings, and to install firmware updates.

Before carrying out a scan project, use the SCENE software to set-up an SD card with project relevant information and settings, like the project structure, scan profiles, or scanner operators. These settings can be transferred to the scanner. For more information on scan project preparation using SCENE, as well as transferring data to the scanner, see the SCENE user manual and [SD Card on page 103](#) section of this manual.

SDHC or SDXC cards are highly recommended. Memory cards with a size up to 64 GB have been verified to operate with the scanner. We recommend using memory cards with a capacity of 4 GB or more. The speed of the card must be Class 10 or better, and its temperature range should be from -20 °C (-4 °F) to 85 °C (185 °F).

NOTE: The SD card must be formatted in the FAT32 file system. When using an SD card other than one supplied with the scanner, format it with the scanner format function first. See [Service on page 101](#)

SDHC cards may also be formatted with Windows. SDXC cards with a capacity of more than 32 GB cannot be formatted with the Windows format function, because Windows formats them in its own file system. The Windows file system is not supported by the scanner. There are freeware tools that allow formatting these cards with Windows as FAT32, but we recommend using the scanner's format function.

NOTICE: Risk of data loss.

Do not remove the SD card from the scanner while it is busy, otherwise you risk corrupting the data on the card. A busy SD card is indicated by the SD card icon blinking in the status bar of the controller software. It is safe to remove the card from the scanner when this icon has disappeared.

When removing a FARO Laser Scanner SD card from your computer, always use the **Safely Remove Hardware** option from the Windows system tray, otherwise you risk corrupting the data on the SD card. To safely remove hardware in Windows, right-click in the system tray, double-click **Safely Remove Hardware** in the context menu, then select the device you want to remove.

File Structure of the SD Memory Card

The file structure of the FARO Laser Scanner SD cards is:

| Name | Size | Type |
|----------|------|-------------|
| Backup | | File Folder |
| Logfile | | File Folder |
| Preview | | File Folder |
| Projects | | File Folder |
| Scans | | File Folder |
| Updates | | File Folder |
| FARO-LS | 0 KB | File |

Figure 7-7 SD Card File Structure

Backup - Scanner backups are saved to this folder. The backup folder is automatically created as soon as you start a scanner backup. See [Backup on page 104](#).

Logfile - When exporting the log files from the scanner, they are saved to this folder. This folder is automatically created by the scanner. See [Log File on page 104](#).

Preview - The preview pictures of captured scans are saved to this folder. The folder is automatically created as soon as you start a scan. See [Starting a Scan on page 47](#).

Projects - Scan projects information is saved to this folder. The folder is automatically created by the scanner. See [Scan Projects and Clusters on page 67](#).

Scans - The captured scans are saved to this folder. The scans folder is automatically created as soon as a scan has been started. See [Starting a Scan on page 47](#).

Updates - Copy firmware updates to this folder. This folder must be manually created. See [Firmware Update on page 107](#).

FARO-LS - Signature file, used to identify the SD card as a FARO Laser Scanner card. This file is automatically created as soon as a scan has been started.

Inserting the SD Card



Figure 7-8 Inserting the SD Card

1. Open the battery compartment cover. The SD card slot is in the lower right.
2. Insert the formatted SD card with the notched edge in the direction as illustrated until it clicks.

NOTICE: Confirm the direction of the memory card before inserting. Using force to insert the memory card in a wrong direction can damage the SD card, card slot, or data on the card.

3. Close the cover.

Ejecting the SD Card

To remove an SD card from the scanner, open the SD card slot cover and lightly push the memory card until it slightly springs out.

NOTICE: Do not eject the memory card while in-use.

Do not let the memory card release from the slot and fall.

Switching on the FARO Laser Scanner

Pressing the scanner's **On/Off button** starts the boot process, indicated by the scanner LEDs blinking blue. If power is supplied by the battery and its charge state is too low to start the scanner, the scanner LEDs blink orange.

When the FARO Laser Scanner is ready, the LEDs stop flashing and illuminate a constantly blue. The scanner controller software's [Frequently Used Buttons on page 55](#) appears on the integrated touch screen.

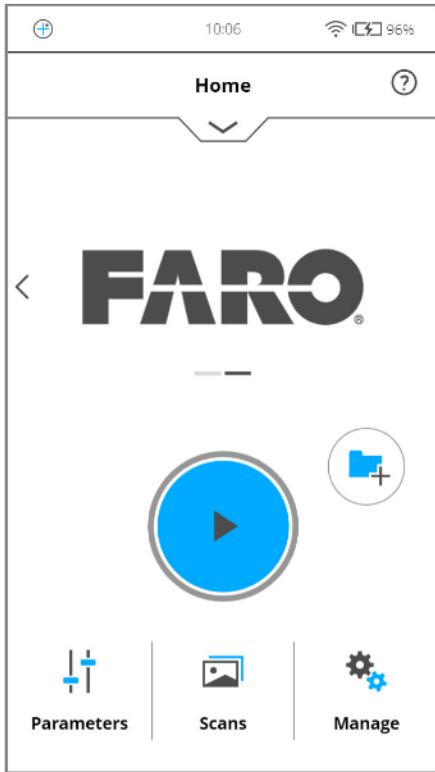

Figure 7-9 Home Screen of the controller software

To operate, tap the elements on the screen with your fingers. You can also use a capacitive stylus to navigate through the user interface.

Initial Scanner Settings

This chapter gives you a brief description on how to set-up initial scanner settings using the scanner's controller software on the integrated touch screen. See [Controller Software on page 53 for more information](#).

Setting the Interface Language

Navigate to [Frequently Used Buttons on page 55](#) > [Manage on page 66](#) > [General Settings on page 85](#) > Language to change the language of the controller software.



Figure 7-10 Language Selection Screen

Select the language by tapping the desired language. The selected language is highlighted.

If the list of available languages exceeds the screen size, scroll up or down.

Setting the Date and Time

To change the date and time settings, navigate to [Frequently Used Buttons on page 55](#) > [Manage on page 66](#) > [General Settings on page 85](#) > Date & Time.

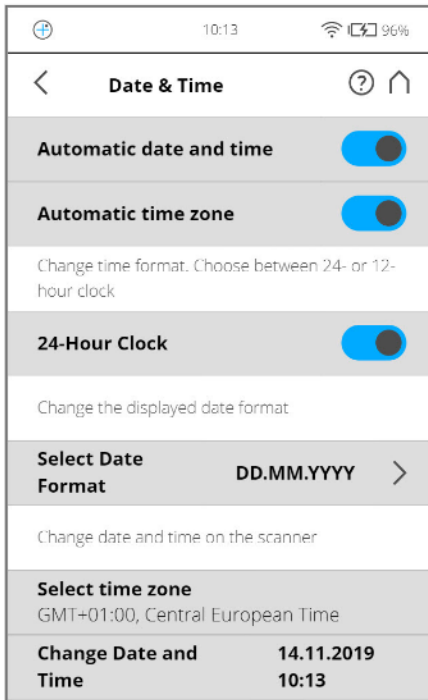

Figure 7-11 Date and Time Settings

Automatic date and time - Tap and slide to activate automatic date and time settings.

Automatic time zone - Tap and slide to activate automatic time zone settings.

24-Hour Clock - Tap to set the time format. The scanner can display time in either the 24-hour or the 12-hour clock format. Slide to ON to select the 24-hour clock. Slide to OFF to select the 12-hour clock.

Select Date Format - Tap to choose the date format. The currently selected date format is displayed.

Select time zone - Tap to select the time zone. The currently selected time zone is displayed.

Change date and time - Tap to set the internal clock.

Setting the Date Format

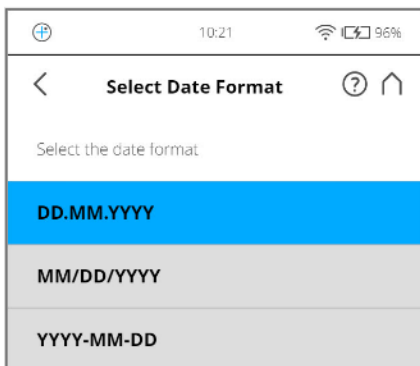

Figure 7-12 Change Date Format

Select the date format by tapping the date. Select between the date formats DD.MM.YYY, MM/DD/YYYY or YYYY-MM-DD, where YYYY is the year, DD the day and MM the month. The selected format is highlighted.

Changing the Date and Time

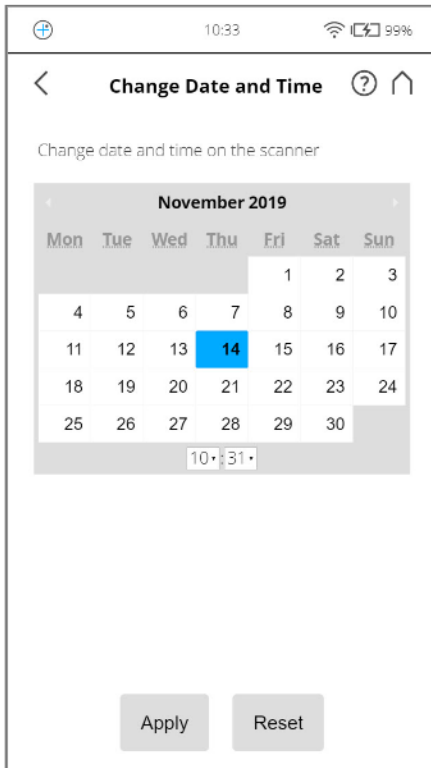

Figure 7-13 Change Date and Time

Select the **time field** in the list to change the time, then use the buttons on the left to set the hours, the buttons on the right to set the minutes.

Select the **year field** in the list to change the year, then use the buttons on the left or on the right to set the date.

Proceed accordingly with the **month** and the **day fields**.

Discard Changes - Tap to discard your changes.

Setting the Unit of Length and the Temperature Scale

Navigate to [Frequently Used Buttons](#) on page 55 > [Manage](#) on page 66 > [General Settings](#) on page 85 > [Units](#).

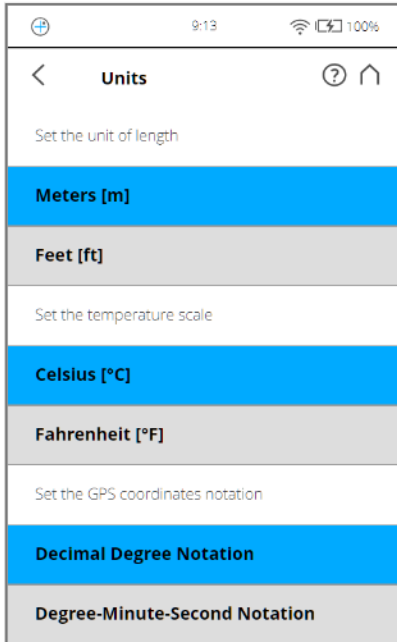

Figure 7-14 Change Unit of Length

Lengths are displayed by the controller software in either in meters or feet. Select the desired unit of length by tapping the corresponding button.

Temperatures are displayed in either Celsius or Fahrenheit. Select the desired unit by tapping the corresponding button.

GPS coordinates are displayed in either decimal degree notation (e.g., +34.9823450 °E) or degree-minute-second notation (e.g., 34° 58' 56.44" E).

Entering Scanner Information

You can specify a scanner name and the owner of the FARO Laser Scanner. Navigate to [Frequently Used Buttons on page 55](#) > [Manage on page 66](#) > [General Settings on page 85](#) > **Scanner Details**.

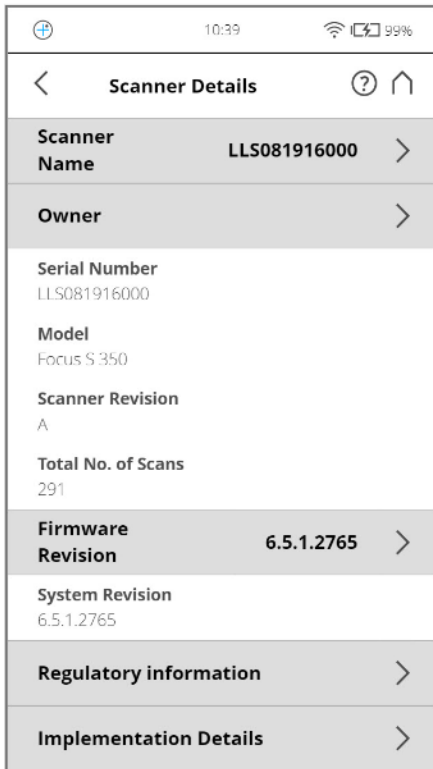

Figure 7-15 Scanner Details

Scanner name - Tap to change the name of the scanner.

Owner - Tap to enter the name of the company or person, who owns the scanner.

See [Scanner Details](#) on page 98.

Scanning

This chapter gives you a brief description on how to set the scanning parameters to capture your first scans. Normally, you would provide and enter project information before starting with your scan project. This is described later. See [Scan Projects and Clusters](#) on page 67.

Setting the Scanning Parameters

Resolution, quality, or scanning angles are the parameters used by the scanner for recording the scan data. There are two ways to set the scanning parameters:

- Change them manually.
- Select a scan profile. These are predefined sets of scanning parameters.

When selecting a scan profile, its settings overwrite the scanning parameters.

To choose a predefined scan profile, or change the scanning parameters, tap **Parameters**.

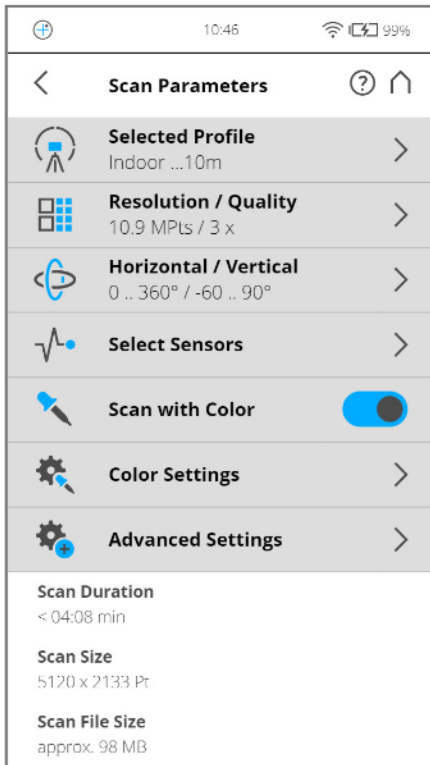

Figure 7-16 Change the Scan Parameters

Selected Profile - Shows the name of the selected scan profile. Tap to select a scan profile. If the scanning parameters differ from the selected profile, *altered* is appended to its name.

NOTE: Selecting a predefined scan profile overwrites all current scanning parameters with the settings of the selected scan profile.

You can also edit the scanning parameters individually by changing the following settings by tapping to edit:

Resolution and Quality - Displays the selected resolution in megapoints, as well as the selected quality.

Horizontal and Vertical Scan Range - Displays the scan range with the horizontal and vertical start and end angles in degrees.

Select Sensors - Opens the screen to enable or disable automatic use of built-in sensors' data for the scan registration in SCENE.

Scan with Color - Switch colored scan recording on or off. If switched on, the scanner also takes color photos of the scanned environment with the integrated color camera or PanoCam accessory, if attached. These photos are taken right after the laser scan and are used in the point cloud processing software SCENE to automatically colorize the recorded scan data.

Color Settings - Shows the current exposure metering mode used for taking color photos. You can also choose whether to use the integrated camera or the PanoCam, an accessory available from FARO. (For more details about PanoCam refer to the [Accessories Manual for the Focus Laser Scanner](#).)

Advanced Settings - Enable or disable the Clear Contour and Clear Sky filters. Enable or disable the Far Distance.

Scan Size [Pt] - Shows the scan size in points horizontal x vertical measurement. The vertical size can only be changed by setting a new resolution or changing the scan area angle.

Scan Duration, Scan File Size - Expected scan time and file size in megabytes depending on the chosen settings, including pre- and post-processing, resolution, selected exposure metering, scan area, quality value, and scan range. Note that the values shown here are approximate values.

Selecting a Scan Profile

Prior to capturing a scan, you can select a scan profile that fits the needs of the scene and the desired scan quality.

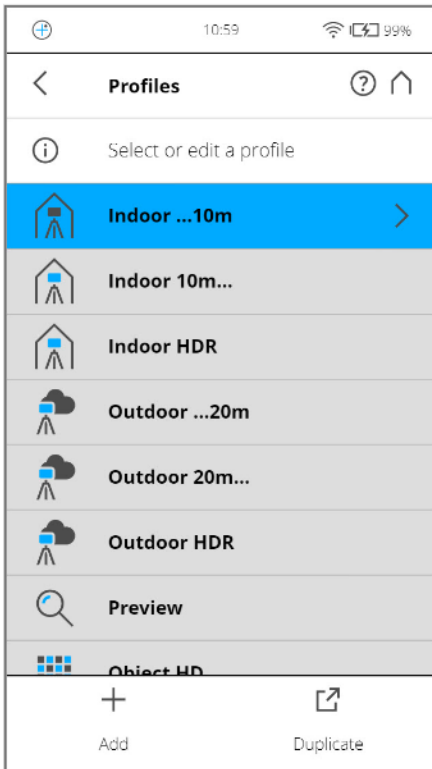

Figure 7-17 Select a Profile

This view shows a list of all available scan profiles. The list contains factory predefined profiles that are read-only and custom profiles that can be created and manipulated under Manage > Profiles.

See [Factory Settings on page 108](#) for an overview of the available factory predefined scan profiles. See [Selected Profile on page 59](#)

Select a profile by tapping it. The selected profile is highlighted.

Setting Resolution and Quality

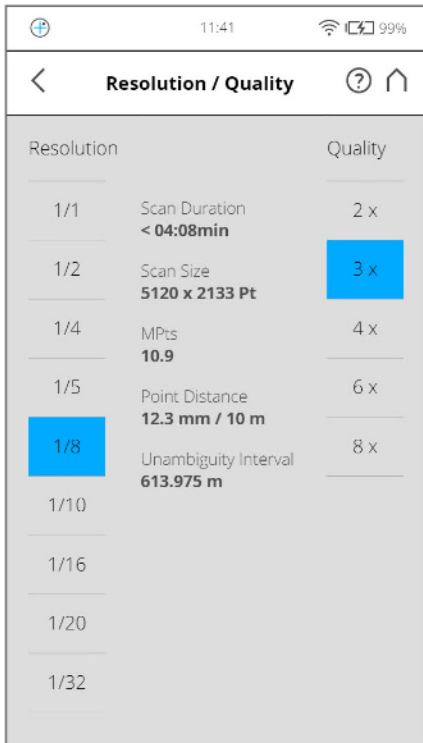

Figure 7-18 Change Scan Resolution and Quality

Resolution - The resulting scan resolution. Choose from 1/1, 1/2, 1/4, 1/5, 1/8, 1/10, 1/16, 1/20 and 1/32.

Quality - The quality of the scan and the scanning time at constant scan resolutions. You can balance the quality and speed. If speed is more important, choose a lower values. If the quality of the scan data is more important, choose higher values.

The resulting scan duration, vertical and horizontal scan points (Scan Size [Pt]), as well as scan size in megapoints (MPts) is displayed in the middle of the view. Point distance [mm/10 m] / [in/30 ft] is the distance between the captured scan points in mm (in) within a scan distance of 10 meters (30 ft).

NOTE: The unambiguity interval specifies the maximum distance at which the scanner can accurately measure points with the selected settings. For technical reasons, points created for objects farther than this distance appear much closer to the scanner than what the objects actually are.

If this happens, remove the points later using the SCENE software. This can be time-consuming. It is quicker to choose a combination of resolution and quality with an unambiguity interval that is larger than the most distant object to be scanned.

If you plan to capture several scans from the same position (with different resolutions), and it is important that these scans have the same horizontal start angle, then you should neither switch off the scanner nor change the quality between the recordings of these scans.

Setting the Scan Range (Scan Area)

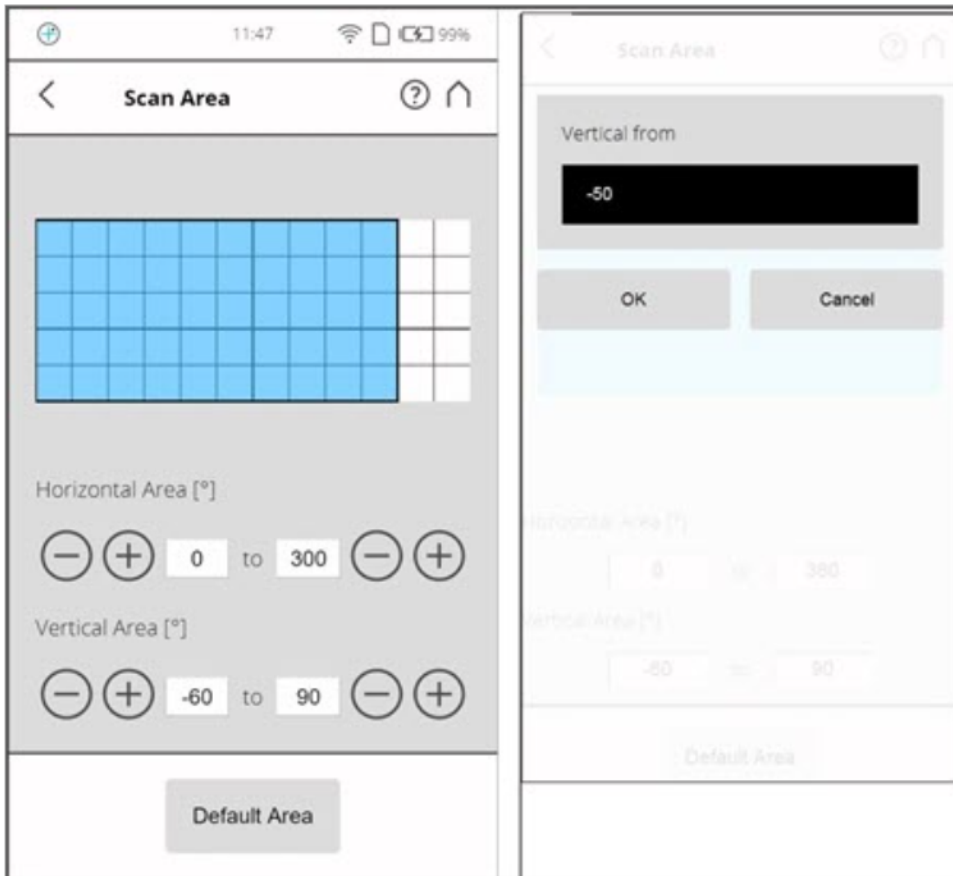

Figure 7-19 Setting the Scan Range

Vertical area - The size of the vertical scan area in degrees. Tap the fields to enter the values of the vertical start and end angles.

Horizontal area - The size of the horizontal scan area in degrees. Tap the fields to enter the values of the horizontal start and end angles.

Default Area - Tap to reset the values to the default scan area (vertical from -60° to 90° and horizontal from 0° to 360°).

The rectangle in this view illustrates the full scan area. If there are scans on the inserted SD card, the preview picture of the last recorded scan is displayed. If there is no preview picture available, a grid is displayed, where the space between the horizontal and vertical lines is equivalent to 30° . The highlighted rectangle illustrates the selected scan area.

Selecting the Sensors

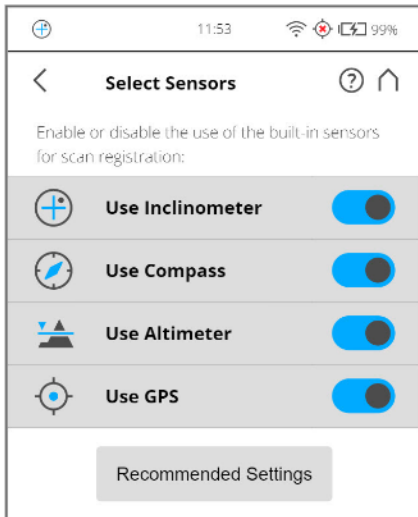

Figure 7-20 Selecting the Sensors

Use Inclinometer - Enable or disable the automatic use of the inclination measurement of the built-in dual-axis compensator (inclinometer) for the scan registration in SCENE. Regardless of your setting, this sensor's data is always measured and attached to each scan. If the inclinometer data is enabled, it is automatically used to register the scans in SCENE; if it is disabled, the data is ignored. You can change this behavior later in SCENE. See the SCENE user manual for more information. Jump directly to **Use Inclinometer** by tapping the quick access icon (⊕) at the top of the screen.

NOTE: To get the most reliable data from the dual-axis compensator, ensure that the scanner's inclination is less than 2°. See [Inclinometer \(Dual-Axis Compensator\)](#) on page 80.

Use Compass - Enable or disable the automatic use of the built-in compass' data for the scan registration in SCENE. The compass' data is always measured and attached to each scan during scanning and is automatically used for the scan registration, if is enabled. If it is disabled, the data is ignored. See [Compass](#) on page 82.

Use Altimeter - Enable or disable the automatic use of the altimeter data for the scan registration in SCENE. As with the inclinometer, the altimeter data is always measured and attached to each scan during scanning and is automatically used for the scan registration, if it is enabled. You can enter a reference height before starting your scan project. This reference height acts as the basis for all measurements made by the altimeter. Find the altimeter settings under Manage > Sensors > Altimeter. See [Altimeter](#) on page 84.

Use GPS - Turns the GPS sensor ON or OFF. Unlike the other sensors, the GPS data is only recorded during scanning and is thus only be available for scan registration in SCENE, if this is switched to ON. See [GPS](#) on page 83.

Recommended Settings - Enable all sensors.

Color Settings

There are two options to capture and colorize scans:

- The integrated camera, see section below
- The PanoCam (an additional accessory available from FARO. For more details about PanoCam refer to the [Accessories Manual for the Focus Laser Scanner](#).)

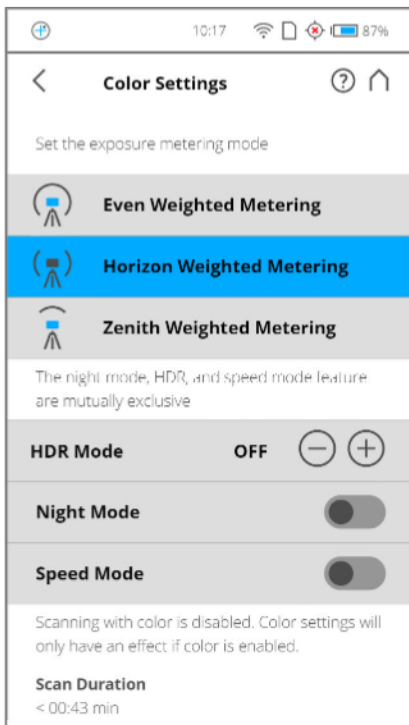

Figure 7-21 Color Settings

Set the exposure metering mode - Set how the integrated color camera determines the exposure for taking the color photos, if colored scan recording is switched on.

Even Weighted Metering - Determine the exposure settings the camera uses regarding the light information coming from the entire scene, and averages without giving weighting to a particular area.

Horizon Weighted Metering - With horizon weighted metering mode, the camera uses the light information coming from the horizon to determine its exposure setting. This mode is commonly used in scenarios with bright light coming directly from above (e.g., indoors with bright ceiling lighting or outdoors in bright sunlight)

Zenith Weighted Metering - With zenith weighted metering, the camera uses the light information coming from above the scanner to determine its exposure setting. Use this mode when there is very bright light coming from windows, for example, and you want to achieve the most correct balance of light and exposure for objects on the ceiling of building.

HDR Mode

The High Dynamic Range (HDR) imaging method merges images captured with different exposure settings into a single image with a greater dynamic range of luminosity.

Scanning with HDR Capturing

Set the HDR capturing by tapping + or -, ranging from 2x to 5x. This setting corresponds to the exposure levels. If no option is selected, then OFF is displayed.

NOTE: When HDR is enabled, a larger number of captured images result in a longer capturing time. The processing time is thus longer in SCENE.

NOTE: The HDR Mode and Night Mode are mutually exclusive. Enabling HDR mode switches off night mode; enabling night mode switches off the HDR mode.

Night Mode

Select night mode to improve the quality of color photos under relatively dark lighting conditions. The image noise is reduced in low-light situations. However, enabling night mode significantly increases the scan duration.

NOTE: For best scanning results, enable **Night Mode** in combination with either **Horizon Weighted Metering** or **Zenith Weighted Metering**. Very dark lighting conditions may lead to a poor picture quality, even if night mode is activated. This can lead to grainy images and other artifacts.

Speed Mode

Select Speed Mode to reduce the scan duration. This happens at the cost of color picture quality. It cannot be combined with HDR or Night Mode.

Advanced Settings

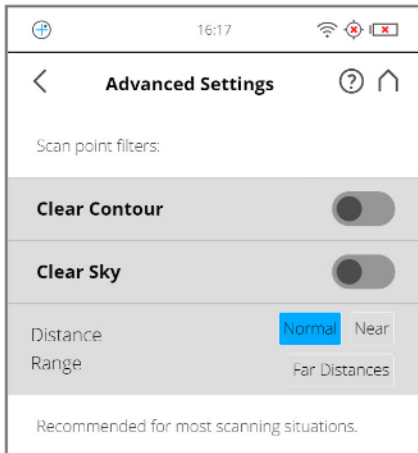

Figure 7-22 Advanced Scanning Settings

Clear Contour - Enables the dynamic contour filter. This hardware filter removes scan points that resulted from the laser spot hitting two objects. This usually happens at the edges of objects.

Clear Sky - Enables the dynamic sky filter. During scanning, this hardware filter removes scan points resulting from scanning empty spaces in the sky.

Distance Range - The Distance Range setting configures the scanner to increase the quality of the points captured at specified distances.

- **Normal** - Select this to scan most objects.
- **Near** - Select this to scan objects that are near the scanner.
- **Far Distances** - Select this when scanning outer-lying spaces, where the scan surfaces are located at distances of greater than 20 meters from the scanner. This setting is not recommended for indoor scanning.

NOTE: Far Distances is not available on all scanner models. See [Introduction on page 2](#).

Recommended Settings - Enables the Clear Contour and Clear Sky filters. Disables Far Distance Optimization.

Scanning Parameters Overview

The following table shows the scanning parameters and net scan time for all resolution and quality settings that are available.

| Resolution | Quality | Mio. Pts (full scan) | Net Scan Time ^a | Point Distance | pt/360° |
|------------|---------|----------------------|----------------------------|----------------|---------|
| 1/1 | ½x | 699.1 | 0:07:22 | 1.5mm/10m | 40,960 |
| 1/1 | 1x | 699.1 | 0:14:38 | 1.5mm/10m | 40,960 |
| 1/1 | 2x | 699.1 | 0:29:07 | 1.5mm/10m | 40,960 |
| 1/1 | 3x | 699.1 | 0:58:19 | 1.5mm/10m | 40,960 |
| 1/1 | 4x | 699.1 | 1:57:18 | 1.5mm/10m | 40,960 |
| 1/2 | ½x | 174.8 | 0:02:02 | 3.1mm/10m | 20,480 |
| 1/2 | 1x | 174.8 | 0:03:49 | 3.1mm/10m | 20,480 |
| 1/2 | 2x | 174.8 | 0:07:23 | 3.1mm/10m | 20,480 |
| 1/2 | 3x | 174.8 | 0:14:36 | 3.1mm/10m | 20,480 |
| 1/2 | 4x | 174.8 | 0:29:07 | 3.1mm/10m | 20,480 |
| 1/2 | 6x | 174.8 | 1:57:18 | 3.1mm/10m | 20,480 |
| 1/4 | 1x | 43.7 | 0:01:15 | 6.1mm/10m | 10,240 |
| 1/4 | 2x | 43.7 | 0:02:01 | 6.1mm/10m | 10,240 |
| 1/4 | 3x | 43.7 | 0:03:45 | 6.1mm/10m | 10,240 |
| 1/4 | 4x | 43.7 | 0:07:21 | 6.1mm/10m | 10,240 |
| 1/4 | 6x | 43.7 | 0:29:06 | 6.1mm/10m | 10,240 |
| 1/4 | 8x | 43.7 | 1:57:18 | 6.1mm/10m | 10,240 |
| 1/5 | 2x | 28.0 | 0:01:24 | 7.7mm/10m | 8,192 |
| 1/5 | 3x | 28.0 | 0:02:29 | 7.7mm/10m | 8,192 |
| 1/5 | 4x | 28.0 | 0:04:46 | 7.7mm/10m | 8,192 |
| 1/5 | 6x | 28.0 | 0:18:40 | 7.7mm/10m | 8,192 |
| 1/8 | 2x | 10.9 | 0:00:48 | 12.3mm/10m | 5,120 |
| 1/8 | 3x | 10.9 | 0:01:06 | 12.3mm/10m | 5,120 |
| 1/8 | 4x | 10.9 | 0:01:57 | 12.3mm/10m | 5,120 |
| 1/8 | 6x | 10.9 | 0:07:22 | 12.3mm/10m | 5,120 |

^a*Net Scan Time* is only the net duration for a laser scan. It does not include processing time for sensors or color picture acquisition.

| Resolution | Quality | Mio. Pts (full scan) | Net Scan Time ^a | Point Distance | pt/360° |
|------------|---------|----------------------|----------------------------|----------------|---------|
| 1/8 | 8x | 10.9 | 0:29:07 | 12.3mm/10m | 5,120 |
| 1/10 | 3x | 7.0 | 0:00:49 | 15.3mm/10m | 4,096 |
| 1/10 | 4x | 7.0 | 0:01:19 | 15.3mm/10m | 4,096 |
| 1/10 | 6x | 7.0 | 0:04:46 | 15.3mm/10m | 4,096 |
| 1/10 | 8x | 7.0 | 0:18:40 | 15.3mm/10m | 4,096 |
| 1/16 | 3x | 2.7 | 0:00:34 | 24.5mm/10m | 2,560 |
| 1/16 | 4x | 2.7 | 0:00:40 | 24.5mm/10m | 2,560 |
| 1/16 | 6x | 2.7 | 0:01:57 | 24.5mm/10m | 2,560 |
| 1/16 | 8x | 2.7 | 0:07:22 | 24.5mm/10m | 2,560 |
| 1/20 | 4x | 1.7 | 0:00:32 | 30.7mm/10m | 2,048 |
| 1/20 | 6x | 1.7 | 0:01:19 | 30.7mm/10m | 2,048 |
| 1/20 | 8x | 1.7 | 0:04:46 | 30.7mm/10m | 2,048 |
| 1/32 | 4x | 0.7 | 0:00:28 | 49.1mm/10m | 1,280 |
| 1/32 | 6x | 0.7 | 0:00:40 | 49.1mm/10m | 1,280 |
| 1/32 | 8x | 0.7 | 0:01:57 | 49.1mm/10m | 1,280 |

Starting a Scan

Remember that the scanner is turning and the mirror unit is rotating at high speeds. Ensure that the scanner can freely move, and that the mirror cannot hit any objects.

Start scanning by tapping on **Start Scan** on the controller software's [Frequently Used Buttons on page 55](#).

NOTE: If there is not enough space on the SD card, you are warned and the scanner refuses to scan. Remove scan data from the memory card, or insert a new card and retry.

When the scan process starts, the scanner's laser is switched ON, and the scanning view is displayed. The scanner's LEDs blink red as long as the scanner's laser is switched ON. During scanning, the scanner rotates 180° clockwise. If you are scanning with color, the scanner continues to turn for a total of 360° to take the pictures.

^a*Net Scan Time* is only the net duration for a laser scan. It does not include processing time for sensors or color picture acquisition.

NOTE: If pictures are taken that include objects that were *not* scanned by the laser, e.g., if a person or vehicle moves into the camera’s field-of-view, you can retake the pictures, if this feature is enabled before scanning. See *For more information, see “Retaking Pictures” on page 131..*

The executed processing steps are displayed in the status area of the scanning screen. The time remaining is indicated by a timer. Tap the drop-down tab to display more information about the scan. The figure below shows the expanded tab.

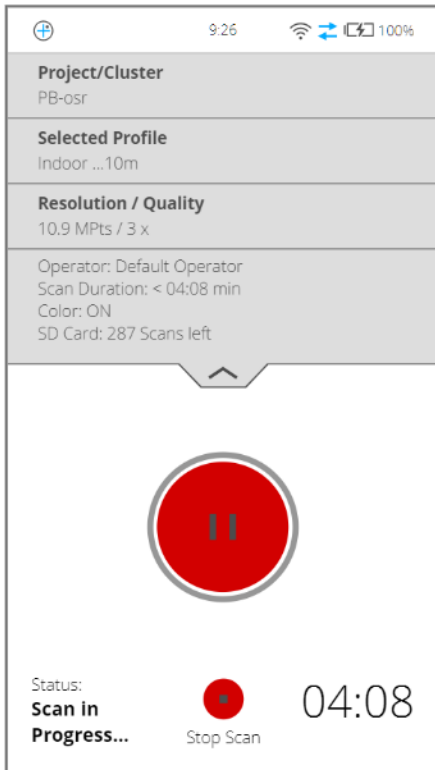

Figure 7-23 Scanning View

During most of the scanning process, a scan can be paused using the pause button. You can pause to avoid scanning a moving object, such as a car or piece of machinery, for example. Resume scanning by tapping the resume button. Avoid pausing the scan while the scanner is scanning a target. Pausing and resuming a scan directly on a target can cause automatic-target detection to fail for that target. Note that it is essential for the scanner to remain absolutely motionless when paused, and we recommend pausing it using a connected browser, rather than tapping the scanner’s screen.

To stop a scan, tap **Stop Scan** in the scanning view. You are then asked whether to keep or delete the incomplete scan.

NOTE: After scanning and picture capturing is complete, depending on environmental conditions, the scanner may make another full turn to capture inclination data. **Do NOT move the scanner** while it is capturing the inclination data, or the inclination data of the scan might be inaccurate and usable for the scan registration.

As soon as the entire scanning process is complete, the scanner plays a notification sound, if not disabled in the settings, and a new screen appears with a preview picture of the captured scan. Now, you can move the scanner to the next scan position and start a new scan.

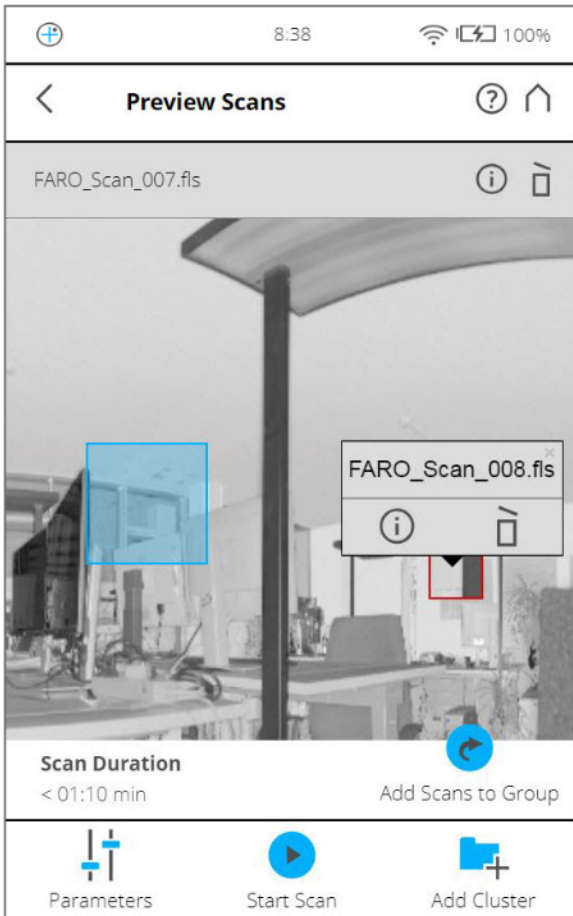



Figure 7-24 Scan Preview

The scan preview shows a gray-scale picture of the captured scan to verify the scan itself, and check if all objects (e.g., targets) are clearly visible. The preview may also contain detail scans belonging to the same scan group. See *For more information, see “Scan Groups” on page 129.*

Parameters - Tap to change the scanning parameters for up-coming scans.

Start Scan - Start a scan.

Tap **Info**  in the pop-up dialog of a selected detail scan to view the scan properties.

Tap **Delete**  to delete the displayed scan. In case of scan groups, only the primary scan, as named in the title, is deleted. Embedded detail scans are not affected.

Tap **Delete** in the pop-up of detail scans to delete the selected detail scan.

Add Scans to Group  See *For more information, see “Scan Groups” on page 129.*

Use the mouse-wheel or pinch gestures to zoom into the preview image.

The **Reset Zoom** button  is only visible when you zoom into the scan picture. This also zooms back out to its original size.

When zoomed in, move the zoomed picture by dragging it with your fingers in any direction.

The **Inclination** in degrees is displayed in the header bar. The following inclination warning message is displayed if the current inclination of the scanner is above 5°.

Strong Scanner Inclination

Inclination of the scanner is not within +/- 5°. This could result in slightly inexact scan measurements."

Try to position the scanner so that its inclination is between +/-5°. To get reliable measurements from the built-in dual-axis compensator, set-up the scanner with an inclination of less than 5° before starting the next scan. To do this, use either a bubble inclinometer at the tripod or the inclinometer screen.

LED Behavior

| Scanner Status | LED at Power ON/OFF button |
|--|----------------------------|
| Scanner off, external power supply not connected | off |
| Regular boot process | flashes blue quickly |
| Battery operation | constantly blue |
| Power On/Off | flashes blue |

| Scanner Status | LED next to the battery |
|--|-------------------------|
| Scanner off, external power supply not connected | off |
| Regular boot process | flashes blue quickly |
| Battery operation | constantly blue |
| Low battery operation at battery state less than 10% | flashes blue |
| Low battery operation at battery state less than 5% | flashes violet |
| AC adapter operation only (no battery) | green |
| Battery charging, state of charge is above 90% (charge done) | cyan |
| Battery charging | orange |
| Battery charging, state of charge less than 10% | flashes orange |
| Battery charging, deep discharge | flashes red |

| Scanner Status | LED next to the battery |
|---|-------------------------|
| Unknown power source. Battery and AC adapter are not detected | constantly red |

Data Security

Scans are **hashed and cryptographically signed** to make detection of whether the recorded scan data has been modified possible. The hash value of a scan can be manually checked on the scanner GUI's *Scan Properties* page. In addition, the hash and signature of a scan can be verified with an external tool that is available on FARO's Knowledge Base (knowledge.faro.com/Hardware/3D_Scanners/Focus/Scan_Verification_Tool_Download_and_Manual).

Shutting Down the FARO Laser Scanner

To shut-down the FARO Laser Scanner, press the **Power On/Off** button for **2 or 3 seconds** or tap the **Power** button in the user interface drop-down list under *Frequently Used Buttons* on page 55. The top LEDs start blinking blue. As soon as the FARO Laser Scanner has finished shutting down, the LEDs stop blinking. You can then safely remove the battery and the power-supply.

CAUTION: Damage to the scanner's internal PC and data loss.

Do not turn-off the power to the FARO Laser Scanner before the shut-down cycle is complete.

The FARO Laser Scanner has an integrated PC with a hard drive. This internal PC must be shut-down before turning off the power-supply. If the power-supply is disconnected or switched off without the FARO Laser Scanner being previously shut-down, it can damage the internal PC and might lead to a data loss.

If the FARO Laser Scanner has not been properly shut-down, the next boot process might require more time than usual, because the FARO Laser Scanner may check its hard disk for errors.

Pressing and holding for more than 10 seconds switches the FARO Laser Scanner off without properly shutting it down. Use this option only if the FARO Laser Scanner will not shut-down, such as due to malfunction.

Powering Off the FARO Laser Scanner

Once the FARO Laser Scanner has been completely shut-down, remove the battery and secure the equipment in protective cases.

1. To remove the battery:
2. Open the battery compartment cover.
3. Release the interlock mechanism of the charger to release the battery.
4. Remove the battery.
5. Close the battery compartment cover.

Chapter 8: Controller Software

General Elements

Status Bar

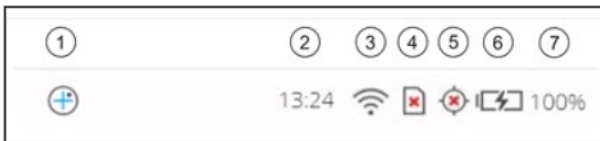







Figure 8-1 Status Bar

- 1 **Inclinometer shortcut**
- 2 **Clock** - Shows the current time. See [Setting the Date and Time](#) on page 33 for information on how to [change the date and time of the scanner](#).
- 3 **WLAN** Status, and the signal strength.
- 4 **SD card status**

| | |
|---|---|
|  | SD card is busy. Do not remove the SD card from the scanner while it is busy, otherwise you risk corrupting the data on the card. |
|  | No SD card inserted. |
|  | SD card is write-protected. Remove write protection to scan using this card. |
|  | Unknown SD card inserted. The card cannot be read. This might be due to the SD card being formatted in an unsupported file system. You should format the SD card with the scanner's format function. See SD Card on page 103. |

- 5 **GPS** Signal

| | |
|---|-----------------------|
|  | GPS signal available. |
|---|-----------------------|

| | |
|--|-----------------------------------|
| | No GPS signal, or vague position. |
|--|-----------------------------------|

6 Battery - Shows the status and charge-state of the internal battery:

| | |
|--|---|
| | Battery is fully charged. |
| | Charge state > 75% and < 100%. |
| | Charge state > 50% and < 75%. |
| | Charge state > 25% and < 50%. |
| | Charge state > 10% and < 25%, you should switch the batter as soon as possible. |
| | Battery is almost empty; FARO® Laser Scanner automatically shuts down within a few minutes. |
| | Battery is charging. |
| | No battery in the FARO® Laser Scanner. |

The exact charge-state of the battery can be viewed under [Frequently Used Buttons on the next page](#) > [Manage on page 66](#) > [General Settings on page 85](#) > [Power Management on page 87](#) (see [Power Management on page 87](#)).

If the charge state of the battery is below 25 percent, you get a warning. Switch to the spare battery as soon as possible.

If the charge state of the battery reaches 10 percent, the FARO® Laser Scanner stops scanning and automatically shuts down.

7 Battery Charge Percent - Shows the exact amount of power remaining in the battery as a percentage.

Navigation Bar

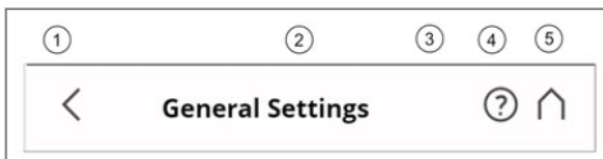









Figure 8-2 Navigation Bar

- 1 Back** - Returns you to the previous screen.
- 2 Screen Name** - Name of the screen that is currently shown.

- 3 **Errors and Warnings** - Only appears, if warning or errors are present. Tap this to open a screen that shows the details of the existing warnings or errors. See [Errors and Warnings on page 102](#).
- 4 **Help** - Opens the online help of the currently active screen, providing access to the user manual. See [Online Help and Notifications on page 110](#).
- 5 **Home** - Returns you to the home screen. See [Frequently Used Buttons below](#).

Frequently Used Buttons

| | |
|---|--|
|  | Add new scan profiles, projects, or operators. |
|  | Duplicates the selected list element, and adds it as a new scan profile, project, or operator. |
|  | Deletes selected list elements, such as projects, scan profiles, or operators. This is grayed-out, if the selected list element cannot be deleted. |
|  | Scroll up and down. Appears at the bottom of the screen, if the content of the screen exceeds the screen height. Tap to scroll up or down. |
|  | |
|  | Opens a new screen with further details or settings. |
|  | Turns functions on or off. Here, the function is turned on. |

Home Screen



Figure 8-3 Home Screen

- ❶ **Start Scan** - Starts a scan. See [Starting a Scan on page 47](#).
- ❷ **Parameters** - Opens the dialog for scan profile selection, or to edit the current scanning parameters. See [Setting the Scanning Parameters on page 37](#).
- ❸ **Info box** - Tap the arrow underneath **HOME** to show or hide the info box. The info box shows information regarding the currently selected operator, project, and scan profile, as well as regarding the current scanning parameters resolution in megapoints, its quality, scan duration, and color.

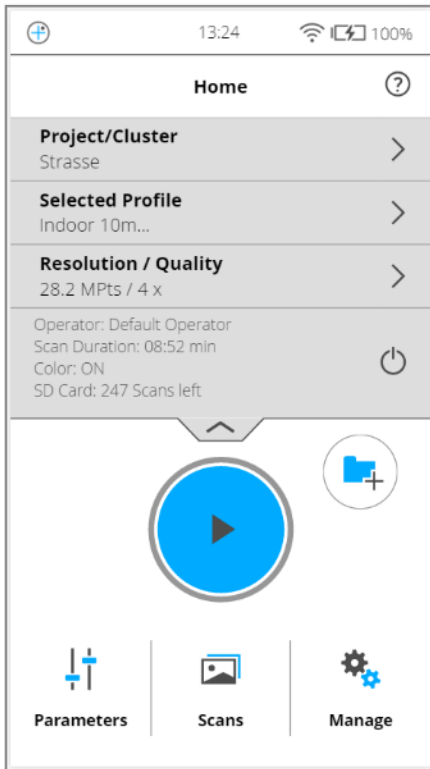

Figure 8-4 Home Screen with Info Box

- 4 **Add cluster** - Add a cluster to the currently selected project.
- 5 **View Scans** - Preview the scans stored on the SD card. See [View Scans on page 109](#).
- 6 **Manage** - Manage scan profiles, projects, operators, and the scanner. See [Manage on page 66](#).
- 7 **Scan Mode** - Tap or swipe to access the on-site registration scan mode.

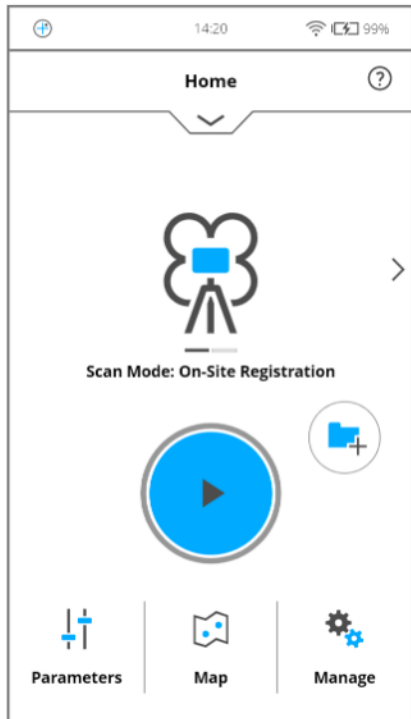

Figure 8-5 On-Site Registration home screen

Scan Parameters

Scanning parameters, like resolution, quality, and scanning angles, are used by the scanner for recording the scan data.

There are two ways to set the scanning parameters:

- manually change them.
- selecting a scan profile, which is a predefined set of scanning parameters.

To select a predefined scan profile or to change the scanning parameters, tap **Parameters** on the *Frequently Used Buttons on page 55*.

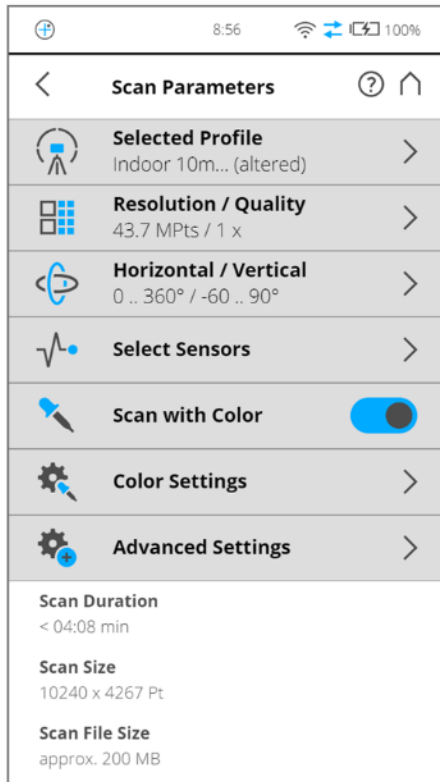

Figure 8-6 Change the Scan Parameters

Selected Profile

Shows the name of the selected scan profile. Tap to select a scan profile. If the scanning parameters differ from the selected profile, **altered** is appended to the name.

NOTE: Selecting a predefined scan profile overwrites all current scanning parameters with the settings of the selected scan profile.

Resolution and Quality

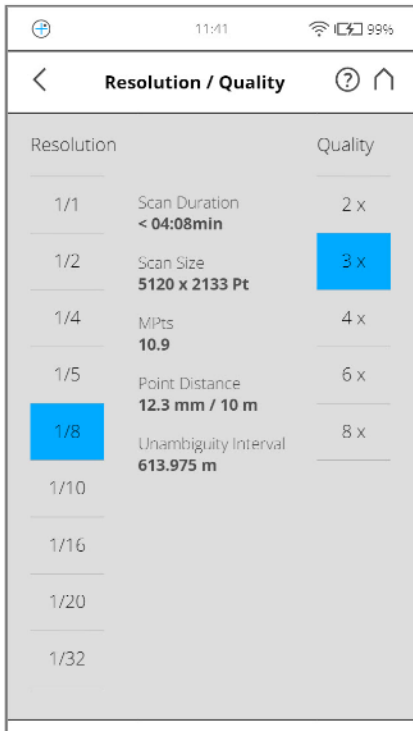

Figure 8-7 Scan Parameters, Resolution, and Quality

Displays the selected resolution in megapoints and the selected quality. Tap to change these values.

Horizontal and Vertical Scan Range

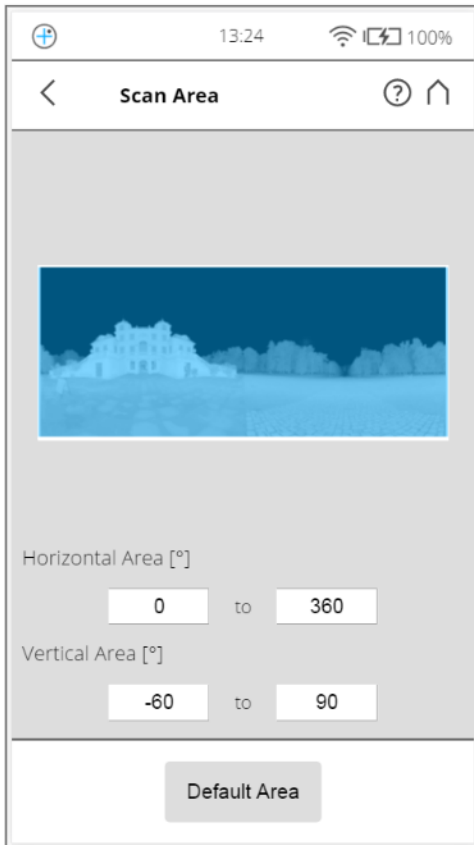

Figure 8-8 Scan Parameters - Scan Area

Displays the scan range with the horizontal and vertical start and end angles in degrees. Tap to adjust them.

Select Sensors

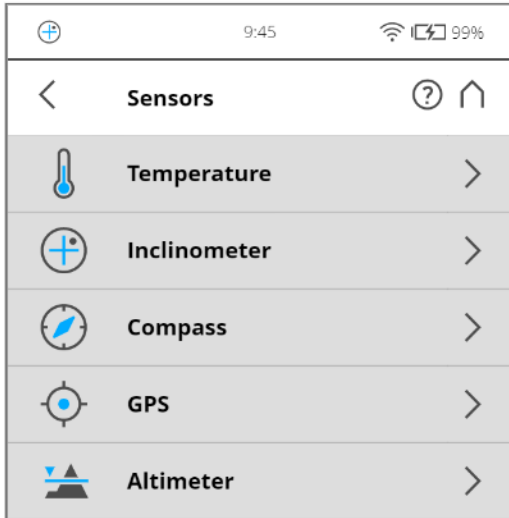

Figure 8-9 Scan Parameters - Select sensors

Opens the screen to enable or disable automatic use of the built-in sensors' data for scan registration in SCENE.

Scan with Color

Switches colored scan recording on or off. If switched on, the scanner also takes color photos of the scanned environment with the integrated color camera, or PanoCam, an additional accessory. (For more details about PanoCam refer to the [Accessories Manual for the Focus Laser Scanner](#).) These photos are taken immediately after the laser scan, and are used in the point cloud processing software SCENE to automatically colorize the recorded scan data.

Color Settings

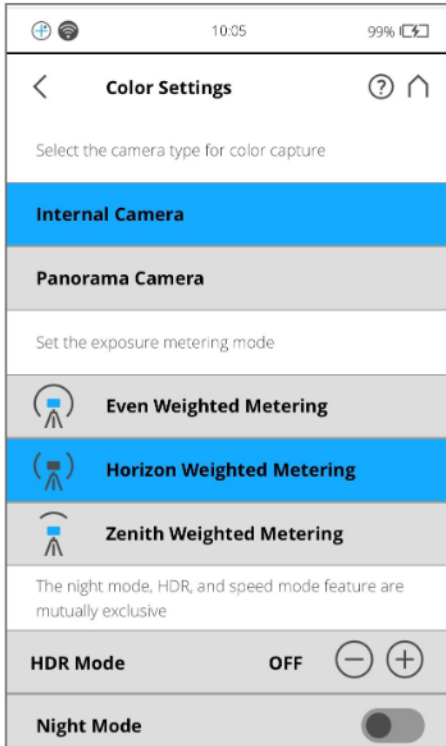

Figure 8-10 Scan Parameters, Color Settings

Set the exposure metering mode - Sets how the integrated color camera determines the exposure for taking the color photos, if colored scan recording is switched on. Select between three exposure metering modes. Choose according to the current lighting conditions to get optimal results.

Even Weighted Metering - To determine the exposure settings, the camera uses the light information coming from the entire scene, and averages without special weighting of a particular area. Use this setting in scenarios with even lighting conditions.



Figure 8-11 Even weighted metering

Horizon Weighted Metering - The camera uses the light information coming from the horizon to determine the exposure setting. This mode is commonly used in scenarios with bright light coming from directly above (e.g., indoors with bright ceiling lighting or outdoors with bright sunlight coming from directly above), or to achieve the best balance of light and exposure for objects at the horizon. This mode is the default setting. Compared to even-weighted metering, this increases scan duration by approximately 14 seconds.



Figure 8-12 Horizon weighted metering

If the vertical scan area is limited, then the area used to determine the exposure (i.e., the exposure metering area) might not be near the horizon. This is the case, if the vertical start angle is set to $> -30^\circ$, or if the vertical end angle is set to $< 30^\circ$. The exposure metering area is then be moved up or down, and set to the center of the remaining vertical scan area. The following figures illustrate this:



Figure 8-13 Exposure metering area (highlighted yellow) for the full vertical scan area



Figure 8-14 Exposure metering area for a limited vertical scan area set to e.g., 10° to 90°

Zenith Weighted Metering - With zenith weighted metering, the camera uses the light information coming from above the scanner to determine its exposure setting. Use this mode, if there is very bright light coming from windows or other sources, or to achieve the best balance between light and exposure for objects on the ceiling, such as ceiling paintings in historical buildings). Compared to even-weighted metering, this mode increases scan duration by approximately 14 seconds.



Figure 8-15 Zenith weighted metering

HDR Mode

See [HDR Mode](#) on page 44.

Night Mode

See [Night Mode](#) on page 44.

Manage

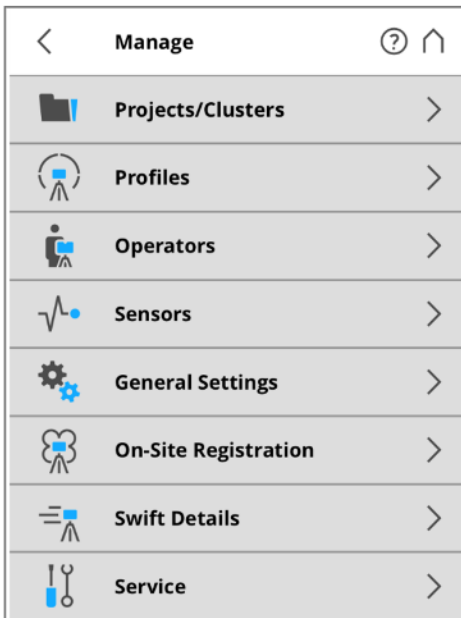

Figure 8-16 Manage

Projects/Clusters

Selects the current scan project; creates a new, or edits an existing, project. Tap to get a list of all available projects. See [Scan Projects and Clusters on the next page](#).

Profiles

Selects the current scan profile; creates a new, or edits an existing, scan profile. See [Scan Profiles on page 73](#).

Operators

Selects the current scanner operator; creates a new, or edits an existing operator. See [Operators on page 77](#).

Sensors

Opens the menu for sensor settings . See [Sensors on page 79](#).

General Settings

Opens the menu for the general scanner settings. See [General Settings on page 85](#).

On-Site Registration

See [On-Site Registration on page 99](#).

Swift Details

See [FARO Swift User Manual](#) for information about Swift.

Service

Opens the menu for scanner services, such as firmware updates, backups, or viewing errors and warnings. See [On-Site Registration on page 99](#).

Scan Projects and Clusters

The Projects/Clusters page displays the structure of your scan projects. A scan project usually consists of a main project that has several sub-projects called clusters. For example, if you are scanning a multi-level building as a project, each floor of this building might represent one cluster, and each of these floors or clusters can have further clusters, for rooms.

The structure of a scan project is similar to this:

- Office building
 - Floor 1
 - Room 1
 - Room 2
 - Room 3
 - Floor 2
 - Room 1
 - Room 2

Before starting a scan project, you can manually enter this structure here. You can reconstruct the complete structure of your scan project within the scanner software, or SCENE SCENE software, then transfer the project to the scanner through using an SD card. Read the SCENE user manual for more information.

Once the project structure has been created, assign the single scans to the corresponding clusters. To do this, select a scan project and cluster before starting a scan. This project should correspond to the current scanner position. For example, if you take scans in the office building on floor 2, in room 2, select *room 2* from the project list, then start taking the scans in that room. The next scans are then assigned to the selected project or sub-project *room 2* until you select another cluster. This information is attached to each scan. It helps SCENE automatically assign scans to scan clusters, thus automating the scan registration. For more information on scan registration and assigning scans to scan clusters, see the SCENE user manual.

You can enter scan projects with the scanner's controller software or, more conveniently, with SCENE, then transfer the project to the scanner using an SD card. Read the SCENE user manual for more information.

NOTE: Every project and cluster receives a unique internal identification number upon creation. Assigning the scans to scan clusters during post processing in SCENE is done according to this identification number, not on the basis of the project name. This is particularly relevant when working with several scanners on the same scan project. In this case, you must create the project structure once as a master, and then transfer it to all of your scanners. Thus, we do not recommend creating or editing a project of the same scan project separately on each scanner. Even if the separately created projects and clusters have the same name, they receive different identification numbers and are treated as different projects by SCENE.

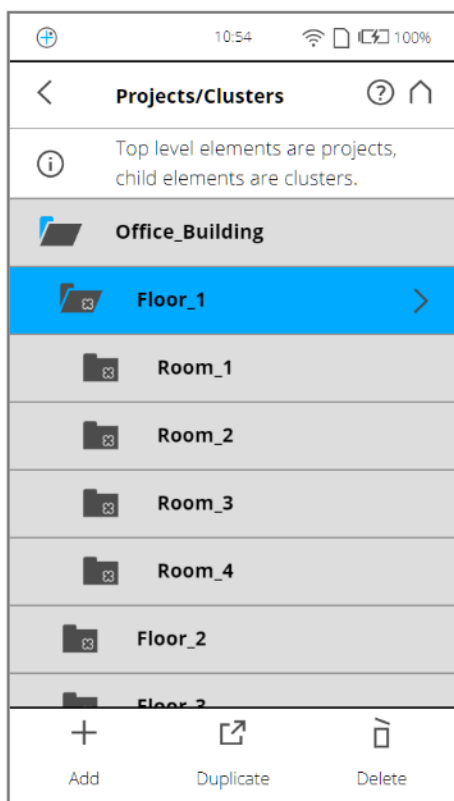

Figure 8-17 Projects List

This view shows a list of all created scan projects/clusters.

The *Default_Project* is a standard project used, when not working in a particular scan project. The *Default_Project* cannot be deleted, and the name of the project, as well as the parent project, cannot be changed.

Add a Scan Project or Cluster

To add a project, tap + at the bottom of the projects list. A new sub-project called *Default_Project.1* is added to the selected project. Tap the field to open its parameters. This opens the View Project/Cluster menu.

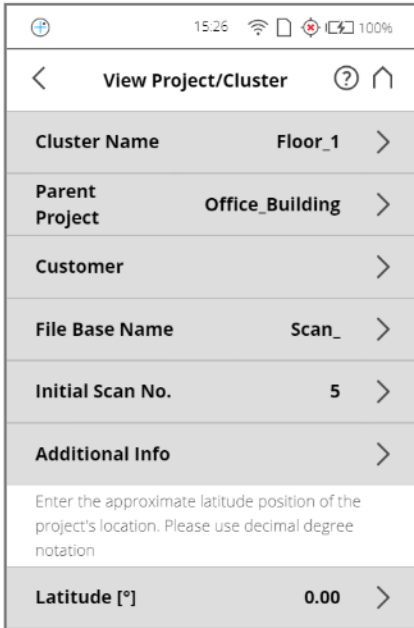

Figure 8-18 View Project

Change the name, and enter further details for the new project. To make the new project the main project without any parent projects, you must either change its parent project to *No Parent Project*, or select the *Default_Project* before adding the new project. With the *Default_Project* selected, new projects are added as the main project without parent projects.

Project Name

Tap to change the name. A name must start with a letter and may contain letters, digits, and underscores.

Parent Project

The parent project of the displayed item. *No Parent Project* means that the current item is a project and not a cluster. Tap to change the parent project or parent cluster. A new screen appears with a list of all available parent projects or parent clusters. Select the parent project/cluster from this list. The currently edited item is then be assigned as a cluster to this project/cluster.

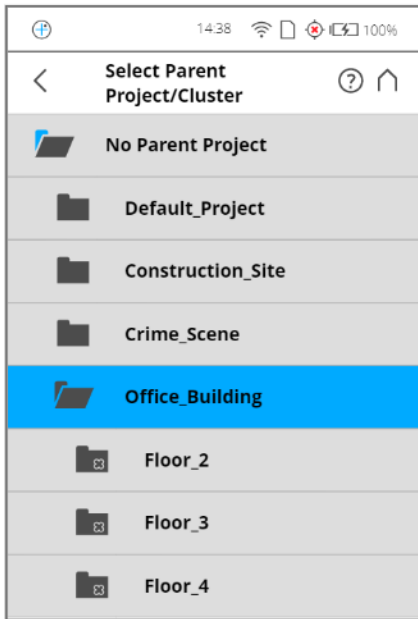

Figure 8-19 Select Parent Project/Cluster

Shows all available projects and clusters eligible to be a parent project/cluster. Tap to select the parent project/cluster. The selected parent project/cluster is highlighted.

No Parent Project

Tap, if the project should not have a parent project.

Project Information

Customer

If you are carrying out the scan project for a customer, you can enter that name here.

File Base Name

The scan is saved with a file name consisting of this base-name, followed by the current scan number.

Initial Scan No.

This automatically increments with each successive scan. It can be reset and can be used to indicate the number of scans per scan session.

Additional Info

Additional project information.

Latitude [°]

Enter the approximate (+/- 10° is sufficient) latitude position of the scan project in decimal degree notation. This information helps to improve the accuracy of the inclination sensor, and leads to better scan registration results.

Duplicate a Scan Project

Instead of adding a new, blank project or cluster, you can create new projects by duplicating existing ones.

To do so, select the project to be duplicated, then tap **Duplicate**  at the bottom of the list. The newly created project has the same settings and properties as the original project.

Delete a Scan Project

Select the project to be deleted in the list and tap **Delete**. If the project or cluster has subordinates, they are also deleted.

How Scan Projects Are Saved

Scan projects are stored on the SD card. If you remove the SD card from the scanner, the entire structure of the currently selected project and cluster, as well as the *Default_Project*, remain on the scanner. All other projects are removed from the list, but are kept on the removed SD card. If you insert a new SD card, the selected project is saved on the new SD card as soon as you make changes to it, or as soon as a scan has been started. If the new SD card already contains projects, the selected project is added to the project list.

Editing a Scan Project

To edit a scan project, select it in the list, then tap it again to reach to its details view.

Selecting a Scan Project

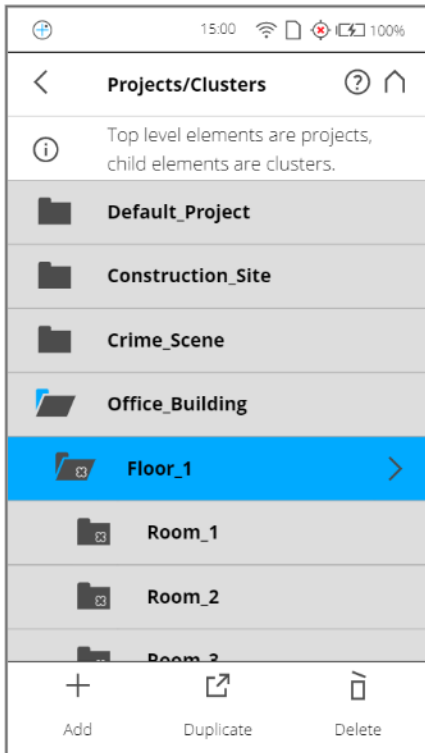

Figure 8-20 Project List

The project list contains the currently selected project, plus all other projects stored on the SD card.

To select a project, tap it in the list. The selected project is highlighted. To view or change details of the selected project, tap it once more.

To display available clusters of a project, select it to expand the list.

If the list of projects exceeds the screen size, scroll up or down with the scroll buttons at the bottom.

Description of Project Button Icons

| | |
|--|--|
| | Project |
| | Cluster |
| | Project has clusters that are currently shown (list is expanded accordingly) |

Scan Profiles

Selecting scan profiles to use their parameters for the next scan has already been described in [Setting the Scanning Parameters on page 37](#). This chapter will describe how to add new and how to edit existing scan profiles.

The **Profiles** page displays a context sensitive toolbar at the bottom to add, duplicate, delete, or modify profiles.

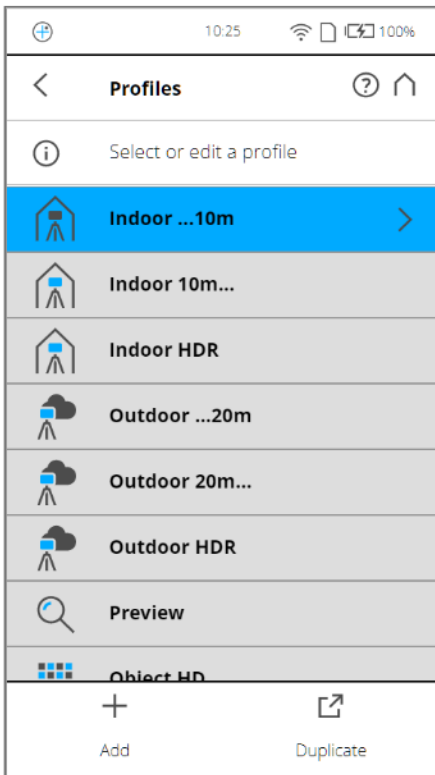

Figure 8-21 Profiles

As previously mentioned, the FARO Laser Scanner comes with factory predefined scan profiles (see [Factory Settings on page 108](#) for an overview of the available factory predefined scan profiles). These scan profiles are read-only, and thus cannot be changed or deleted, but you can add and manage your own custom scan profiles.

This view shows all scan profiles that are available on the scanner.

To add a new profile, tap **Add**. You can also add new profiles by duplicating existing profiles. To do this, select the profile that you want to duplicate and tap **Duplicate**. Tap again on the profile. A new screen appears. Enter the profile name, and adjust its scan parameters.

To delete a custom scan profile, select it and tap the **Delete** button. You cannot delete factory predefined profiles.

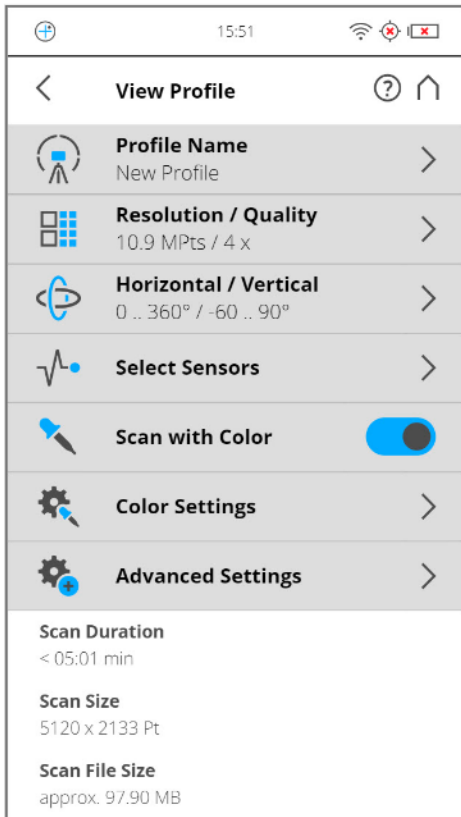

Figure 8-22 Scan Profile Details

Profile Name - Name of the scan profile. Tap to change it.

The further settings in this view are similar to the settings of the scanning parameters. See [Scan Parameters](#) on page 58.

Editing a Scan Profile

To edit a scan profile, select it in the list and tap it again to view its details. You cannot edit predefined profiles.

To view the details of the selected profile, tap it again.

Factory Predefined Scan Profiles Overview

| | Indoor... 10 m | Indoor 10 m... | Outdoor... 20 m | Outdoor 20 m... | Preview | Object HD |
|-------------|---|-----------------------------------|------------------------------------|------------------------------------|---------------------------------------|--|
| Description | Scan indoors, where the distances from the scanner to | Scan indoors, where the distances | Scan outdoors, where the distances | Scan outdoors, where the distances | Capture a fast and rough preview scan | Scan certain objects or areas in very high resolution. |

| | Indoor... 10 m | Indoor 10 m... | Outdoor... 20 m | Outdoor 20 m... | Preview | Object HD |
|--|--|---|--|---|---------------------------------------|---|
| | the main objects of interests are less than 10 m | from the scanner to the main objects of interests are greater than 10 m | from the scanner to the main objects of interests are less than 20 m | from the scanner to the main objects of interests are greater than 20 m | of the environment in low resolution. | It is recommended to limit the scan area to the object or area of interest, else the scan might take very long to complete. |
| Quality | 3x | 4x | 4x | 4x | 4x | 6x |
| Vertical Area | -60° - 90° | -60° - 90° | -60° - 90° | -60° - 90° | -60° - 90° | -60° - 90° |
| Hor. Area | 0° - 360° | 0° - 360° | 0° - 360° | 0° - 360° | 0° - 360° | 0° - 360° |
| Inclinometer | ON | ON | ON | ON | ON | ON |
| Compass | ON | ON | ON | ON | ON | ON |
| Altimeter | ON | ON | ON | ON | ON | ON |
| Use GPS | OFF | OFF | ON | ON | ON | ON |
| Color | ON | ON | ON | ON | OFF | ON |
| Clear Contour | ON | ON | ON | ON | ON | ON |
| Clear Sky | ON | ON | ON | ON | ON | ON |
| Distance Range | Near | Near | Normal | Far Distances | Normal | Near |
| The following values refer to full area scans (360° horizontally / 300° vertically): | | | | | | |
| Resolution (MPts) | 11 | 28.2 | 28.2 | 44 | 2.8 | 176.0 |
| Net Scan Duration (hh:mm:ss) | 00:05:11 | 00:08:52 | 00:08:52 | 00:09:12 | 00:01:27 | 01:58:49 |
| Scan File Size (mb) | 190.70 | 243.88 | 243.88 | 171.18 | 8.53 | 2338.20 |
| Scan Size (Pt) | 5156 x 2134 | 8248 x 3414 | 8248 x 3414 | 10310 x 4268 | 2578 x 1068 | 20622 x 17066 |

Factory Predefined Scan Profiles Overview

| | Indoor HDR | Outdoor HDR | Outdoor: Far Distances |
|--|--|---|---|
| Description | Scan indoors, where the distances from the scanner to the main objects of interests are less than 20 m with HDR quality. | Scan indoors, where the distances from the scanner to the main objects of interests are more, with HDR quality. | Scan outdoors, where the distances from the scanner to the main objects of interests are far. |
| Quality | 4x | 4x | 4x |
| Vertical Area | -60° - 90° | -60°...- 90° | -60° - 90° |
| Horizontal Area | 0° - 360° | 0° - 360° | 0° - 360° |
| Inclinometer | ON | ON | ON |
| Compass | ON | ON | ON |
| Altimeter | ON | ON | ON |
| Use GPS | OFF | ON | ON |
| Color | ON | ON | ON |
| Clear Contour | ON | ON | ON |
| Clear Sky | ON | ON | ON |
| Distance Range | Normal | Normal | Normal |
| The following values refer to full area scans (360° horizontally / 300° vertically): | | | |
| Resolution (MPts) | 28.2 | 44 | 44 |
| Net Scan Duration (hh:mm:ss) | 00:07.42 | 00:10:16 | 00:11:27 |
| Scan File Size (mb) | 243.88 | 292.95 | 292.95 |
| Scan Size (Pt) | 8248 x 3414 | 10310 x 4267 | 10310 x 4267 |

NOTE: When taking color scans, **Night Mode** may significantly increase the exposure time, leading to a much longer overall scan times.

NOTE: Outdoor: Far Distances is not available on all scanner models. See [Introduction on page 2](#).

Operators

Information about which scanner operator has recorded which scans can be useful for the person who is post-processing the scans, especially when there are several scanner operators working on the same scan project.

You can assign scanner operators to the captured scans. To do this, select the operator in the operators list. Create an operator profile, if it does not already exist. The information regarding the selected operator is stored in the data of the next scans, and can be accessed in SCENE during the post-processing of scans.

Creating an Operator Profile

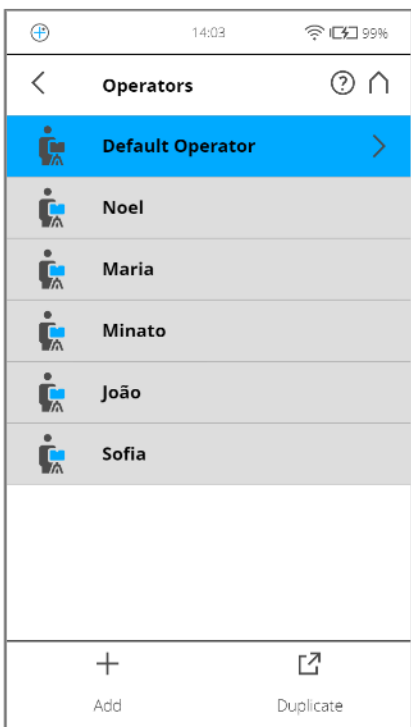

Figure 8-23 Operator Profiles list

To add a new operator profile, tap **Add**. You can also add new operator profiles by duplicating an existing operator profile. To do this, select the operator profile you want to duplicate and tap **Duplicate**. Tap again to view a screen, and enter the operator profile details.

To delete an operator profile, select it and tap **Delete**.

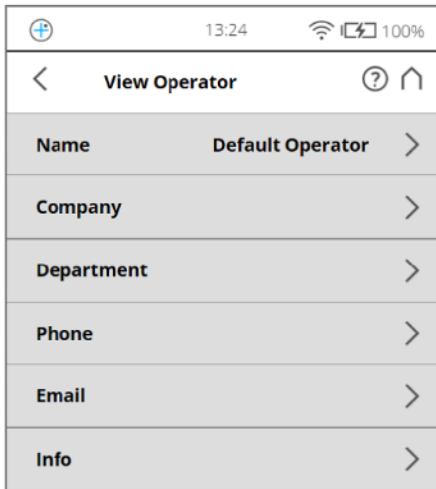

Figure 8-24 Operator Profile details

Name - The name of the scanner operator.

Company - The name of the company providing the scanning service.

Department - The department the operator works for.

Phone - The operator's phone number.

Email - The operator's email address.

Info - Any additional information required by the service provider or shift leaders, project managers, etc.

Editing an Operator Profile

To edit an operator profile, select it in the list and tap it once again to find its details.

Selecting an Operator Profile

Select an operator profile in the list by tapping the corresponding button. The selected operator profile is highlighted, and assigned to the captured scans, until another operator profile is selected. To view or edit the details of the selected operator profile, tap it again.

Sensors

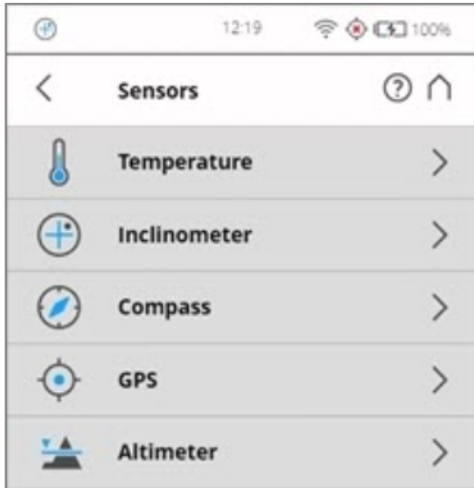

Figure 8-25 Sensors

Temperature - Tap to view the current scanner temperature and to switch the scanner's fan on or off. See [Temperature Sensors](#) below.

Inclinometer - Tap to level the scanner. See [Inclinometer \(Dual-Axis Compensator\)](#) on the next page.

Compass - Tap to view the orientation of the scanner. See [Compass](#) on page 82.

GPS - Tap to view details regarding the current GPS position and accuracy. See [GPS](#) on page 83.

Altimeter - Tap to view the currently measured altitude of the scanner's position and to sync the altimeter with a reference height. See [Altimeter](#) on page 84.

Temperature Sensors

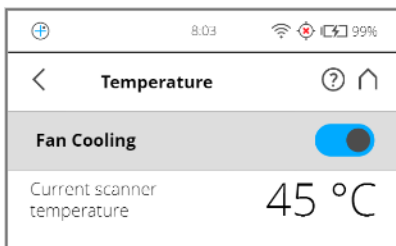

Figure 8-26 Temperature Sensors

The scanner has several integrated temperature sensors that measure the temperature at different points inside the scanner. This screen shows the temperature of the sensor with the currently most critical value.

If a sensor is outside of the recommended operating temperature, but not yet critical, the temperature display is highlighted in yellow. Scanning is still possible, but we recommend letting the scanner either warm-up or cool-down until the temperature display is again highlighted in green.

If the temperature is too high or too low, the temperature display is highlighted in red. In that case, scanning is not possible. The scanner shuts down within a few minutes.

Fan cooling switches the scanner's integrated fan on or off.

If the temperature is above the critical limit, ensure that the fan is switched on. If not, switch it on.

NOTICE: Switch the fan off in exceptional cases only!

If the fan is switched off for long periods, the scanner can overheat, resulting in an aborted scanning process or causing damaged.

Inclinometer (Dual-Axis Compensator)

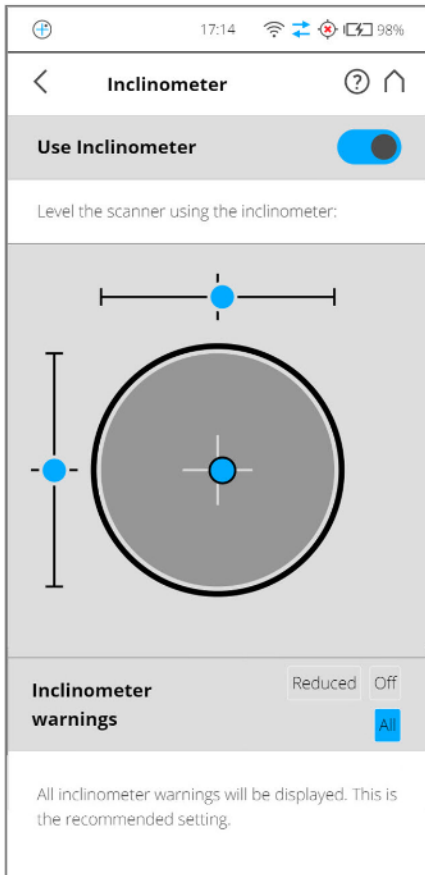

Figure 8-27 Inclinometer

Level the Scanner Using Inclinometer

The view displays a bulls-eye bubble level inclinometer, as if it were mounted on top of the scanner. If the background color is gray, the inclinometer is leveled within 2 degrees. The background color of the inclinometer turns yellow, if the scanner is tilted more than 2°. In this case, the accuracy of the inclination measurement is reduced.

If the inclination is larger than 5°, the background color of the level will turn red. This has two consequences:



- The inclinometer accuracy is further reduced
- The scan quality may be affected.

The two linear levels describe the direction of inclination: If the bubble in the upper level is on the left side, the scanner is tilted to the right, if you are standing in front of the display. If the scanner is tilted towards you, the bubble in the left level is in the upper half.

NOTE: The inclinometer needs to know the latitude of the scanner to compensate for natural variations in the earth's gravitational field. Without this information, scans in a project may have an incorrect inclination, which can increase registration errors.

If you use the inclinometer, ensure that you set the latitude for the project. See [Latitude \[°\]](#) on [page 70](#).

Inclinometer Warnings

The Inclination Warning icon in the header bar is only visible, when the current inclination of the scanner is above 2°, in which case it is yellow . The icon becomes red , if the scanner is tilted more than 5°.

To get reliable measurements from the built-in dual-axis compensator, you must set up the scanner with an inclination less than 5° before starting your next scan. Note that inclinations greater than 2° are measured with less precision, which can affect the scan registration. To align the scanner, you can use either a bubble inclinometer at the tripod or the inclinometer screen.

The displayed warnings can be configured as follows:

All

An inclinometer warning is displayed, if the scanner is tilted more than 2°. This is the recommended setting.

Reduced

An inclinometer warning is displayed, if the scanner is tilted more than 5°.

Off

No inclinometer warnings is displayed in the header bar. (Not recommended.)

Compass

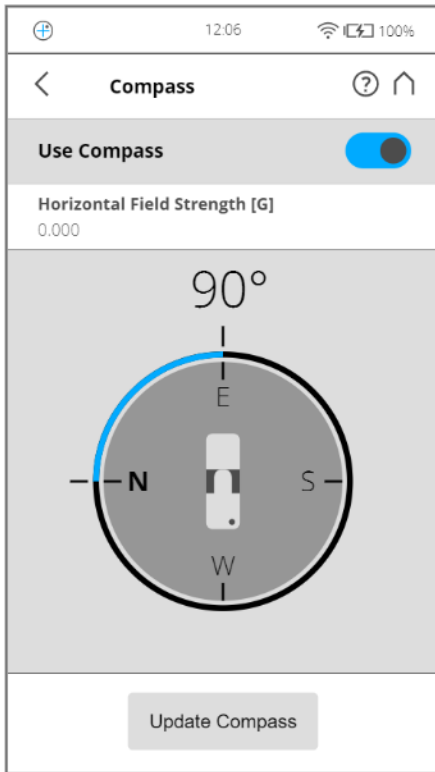

Figure 8-28 Compass

The built-in electronic compass measures the orientation of the scanner on the earth's surface. This information is useful for the registration process.

It is attached to each scan and can be used for the scan registration in SCENE. See the SCENE user manual for more information.

If you want SCENE to use the compass data for the scan registration, switch the **Use Compass** function to ON. Otherwise, switch it to OFF. This setting affects the current scanning parameters, and has the same function as the equivalent button in the parameters settings. See [Setting the Scanning Parameters on page 37](#).

You can monitor the current orientation of the scanner on this screen. Initially, when entering this screen, the orientation is not displayed. To see the current orientation of the scanner, tap the **Update Compass** button on the bottom. For the measurement, the scanner needs to turn horizontally by 360°. Ensure that the scanner can move freely, and do not move the scanner during the measurement.

As soon as the scanner has completed the rotation and determined its orientation, a compass is displayed as if it were mounted on top of the scanner. This compass illustrates the current scanner orientation. Additionally, the measured orientation value is displayed in degrees.

To get updated orientation data, for example, if the scanner has been moved to another position, tap **Update Compass** again.

This manual compass measurement only affects the output on this screen. It is not necessary for the orientation data measured during scanning. During scanning, an orientation measurement is automatically performed.

The accuracy of compass measurements can be affected by environmental interference, such as magnetic interference. An indicator of the strength of environmental interference, and thus of the current compass measurement accuracy, is the displayed **Horizontal field strength** of the magnetic field. The typical strength of the earth's magnetic field depends on geographical position and varies from 0.3 to 0.6 gauss (G). The displayed horizontal field strength is lower than the absolute field strength because of the inclination of the field. For example, the typical horizontal field strength for Europe is about 0.2 gauss.

If the measured field strength differs significantly from the expected field strength, there might be a strong, artificial magnetic field near the scanner that is affecting the measurement. To get the most reliable orientation data for the scan registration, avoid positioning the scanner near strong magnetic fields. If the measured horizontal field still significantly differs, switch the compass data to OFF.

NOTE: Ferromagnetic objects and electromagnetic fields can disturb the earth magnetic field. This, as well as local variations in earth magnetic field (magnetic declination/variation) can lead to inaccurate compass measurements. In this case it's recommended to switch off the use of the compass data.

GPS

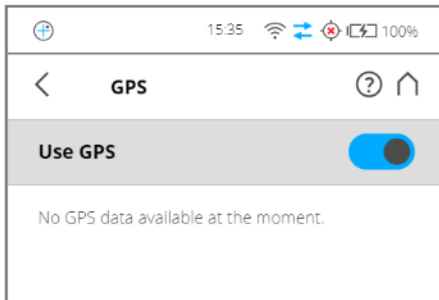

Figure 8-29 GPS

The scanner's position information provided by the built-in GPS sensor is attached to each scan, and is automatically used for the scan registration in SCENE, if the GPS sensor is switched ON.

Use GPS - Turn the GPS sensor ON or OFF. Unlike the other sensors, GPS data is only recorded and attached to each scan, if this sensor is turned ON. This function is also available under [Scanning Parameters Overview](#) on page 45. For more information, see [Setting the Scanning Parameters](#) on page 37

After the GPS sensor is switched ON, it automatically begins searching for GPS satellites. Note that it can take a few minutes to find all available satellites, and to determine precise positional information. We recommend switching the GPS sensor OFF, if it is not needed, or if a GPS signal is not available. If you are scanning indoors, for example.

GPS information - Provides information about the currently-measured GPS coordinates, including the latitude, longitude, and altitude, as well as the UTC time of the last satellite contact and the number of satellites that are currently in view. The GPS receiver needs the signal of at least three satellites to calculate

a 2D position (latitude and longitude). With four or more satellites in view, the receiver can determine the scanner's 3D position (latitude, longitude, and altitude).

The signal strength bars below the GPS information appear for each satellite in view with the appropriate satellite number underneath. These indicate the signal strength for each satellite.

GPS precision - Provides information about the precision of the currently measured coordinates in meters or feet. The DOP (dilution of precision) values are an indicator of the current satellite constellation geometry's quality. In general, good position measurements can be achieved, when the satellites are located at wide angles relative to each other. In this case, the DOP values are low. Higher DOP values indicate a poor satellite geometry, which might have a negative effect on the position accuracy.

The current GPS status and signal quality is indicated by different GPS icons in the status bar of the operating software.

Before starting a scan, you should always look at the GPS icon and the indicated quality. If no GPS data is available or position deviation is high, try to find a position with better signal quality.

A limited GPS signal can have many different causes. As with portable navigation devices, make sure that the scanner always has an unobstructed view of the sky. Obstructions can block the signal reception, causing position inaccuracy or no position data. The GPS signal can also be reflected by objects (for example, buildings or mountains), causing the measured position to wander. The more satellites the sensor has in view, the better the fix is.

Altimeter

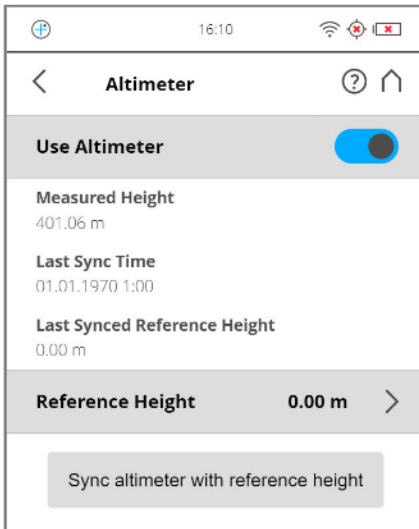

Figure 8-30 Altimeter

The barometric height sensor (altimeter) determines the altitude of the current scanner position. The altitude determination is based on the measurement of the atmospheric pressure. The measured altitude is attached to each scan, and can be used for the scan registration in SCENE. See the SCENE user manual for more information. If you want SCENE to automatically use the measured altitude for the scan registration, switch the **Use Altimeter** to ON; else switch it to OFF. This setting affects the current scanning parameters, and has the same function as the equivalent button in the parameters settings. See [Setting the Scanning Parameters on page 37](#)

To see the currently measured altitude on this screen, the altimeter must be switched ON.

For scan registration, you need only know the difference in altitude of the various scanner positions. Before starting your scan project, you should pick a position for your scanning site that you would like to use as the reference for the altitude measurements. Move the scanner to this reference position, enter any height you would like to use for this position, then reset the altimeter to this reference height by tapping **Sync Reference Height**. All further altimeter measurements are then done based on this reference height.

If you want comparable height measurements across different projects, sync the altimeter with a real altitude. Pick a reference position of your scanning site, where you know the approximate **altitude above sea level**. You can get this value from a GPS, topographic map, or from Google Earth.

Since the altimeter determines the altitude based on the atmospheric pressure measurement, changes in air pressure caused by changing weather conditions effect the resulting altitude. To get precise altitude measurements, periodically check the reference altitude; at least at the beginning of each project day and when the weather changes. To do this, move the scanner back to your reference position, and compare the altitude reading with the reference height. If there is a difference, re-sync the altimeter with the reference height.

General Settings

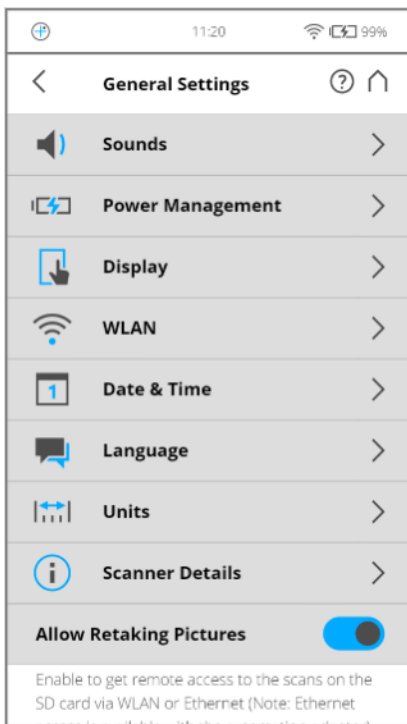

Figure 8-31 General Settings

Sounds - Change the volume of the scanner sounds. Enable or disable scanner sounds. See [Sounds on the next page](#)

Power Management - View detailed settings regarding the administration of power, such as the battery charge level. Enable or disable start on power. Modify display settings to optimize power usage. See [Power Management on page 87](#)

Display - Set the brightness of the screen or change the theme of the Home screen to **Dark** or **Bright**. See [Display on page 88](#)

Date & Time - Change the displayed time and date format, or change the date and time of the scanner. See [Setting the Date and Time on page 33](#).

Language - Change the language of the controller software. See [Setting the Interface Language on page 32](#).

Units - Change the displayed unit of lengths. See [Setting the Unit of Length and the Temperature Scale on page 35](#).

Scanner Details - View and change details of the scanner. See [Scanner Details on page 98](#)

Allow Retaking Pictures - Enable the ability to retake any pictures with the internal camera immediately after the scan completes. Note that when this option is enabled, you must take extra steps to close the scan. See [Retaking Pictures on page 131](#).

Remote Access to Scans Enabling this function gives you access to the scans on the inserted SD card on remote devices that are connected to the scanner through WLAN or Ethernet. For more information, see [WLAN on page 88](#)

NOTICE: Risk of data loss

- Use only if you're about to access scan files through a network. DO NOT remove the SD card until remote access is disabled.
 - The status of the SD card is set to busy as long as this function is enabled. Disable it before you remove the SD card from the scanner. Remote access is automatically disabled, when shutting down the scanner. You must re-enable it after reboot.
-

Sounds

The scanner has a built-in speaker. The scanner signals certain events with various sounds. You can change the speaker volume here, as well as switch the sound effects ON or OFF.

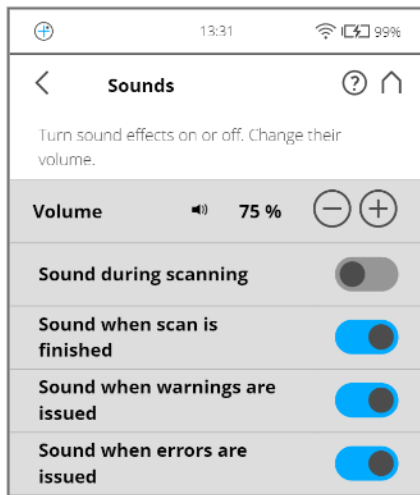

Figure 8-32 General Settings, Sounds

Volume - Increase or decrease the volume of the scanner sounds.

Sound during scanning - If switched on, the scanner plays a warning signal, when laser is switched on and scanning starts.

Sound when scan is finished - If switched on, the scanner plays a sound when scanning is complete.

Sounds when warnings are issued - If switched on, the scanner produces a warning sound when a warning is issued.

Sounds when errors are issued - If switched on, the scanner produces a sound when an error is issued.

Power Management

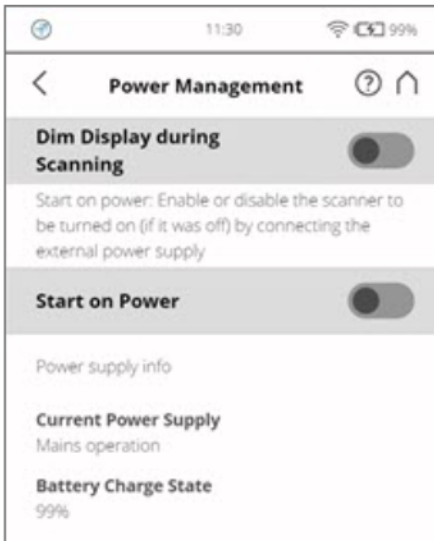

Figure 8-33 General Settings, Power Management

Screensaver - If the screen has not been touched for a certain period of time, a screensaver appears on the screen. Change the length of time before the screensaver appears by tapping plus or minus. Deactivate the screensaver by setting the time to *never*. When the screensaver is visible, tap the screen to return to operation mode.

Dim display during scanning - If switched on, the brightness of the screen decreases during scanning to save battery power. Switching this ON is particularly useful for long scans.

Start on Power - Enable the scanner to be turned on, if it was turned off, by connecting it to the external power-supply. This is useful for automation applications, for example.

Power supply info - Gives information regarding the current power-supply source and the charge-state of the battery.

Display

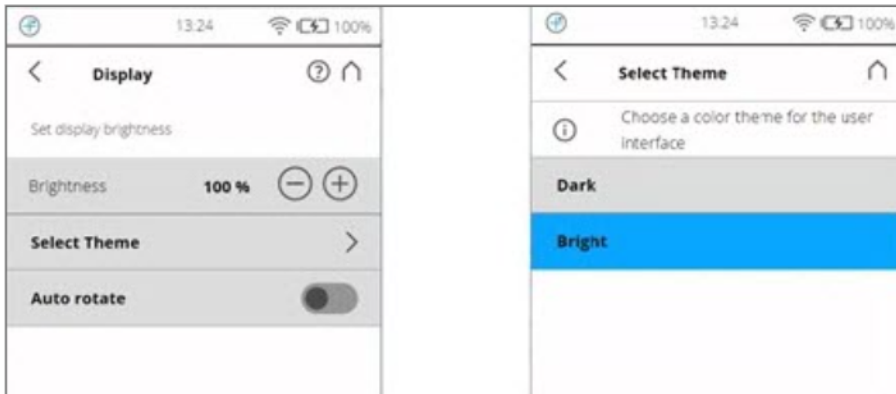

Figure 8-34 General Settings, Display

Brightness - Set the brightness of the screen.

Select Theme - Change the theme of the **Home** screen to **Dark** or **Bright**.

Calibrate the display - If the touch screen seems slightly misaligned, recalibrate it. Tap this and follow the instructions. We recommend using a stylus to calibrate the display. If the touch screen calibration is corrupted, you must reset the display calibration to its factory settings.

- Shut-down the scanner using the **Power** button.
- Wait until the scanner has shut-down completely, then press and hold the power button for at least five seconds, until the LED on the sensor side of the scanner illuminates yellow, then release the button. The scanner then boots up and resets the touch screen calibration of the to its factory settings.

Auto rotate - Turn-on to let the display rotate, depending on the scanner orientation. This is helpful when the scanner is located upside down.

Date and Time

See [Setting the Date and Time](#) on page 33.

Language

See [Setting the Interface Language](#) on page 32.

Units

See [Setting the Unit of Length and the Temperature Scale](#) on page 35.

WLAN

The WLAN interface can be used for remote connections, especially if your scanner is not equipped with an automation interface connection.

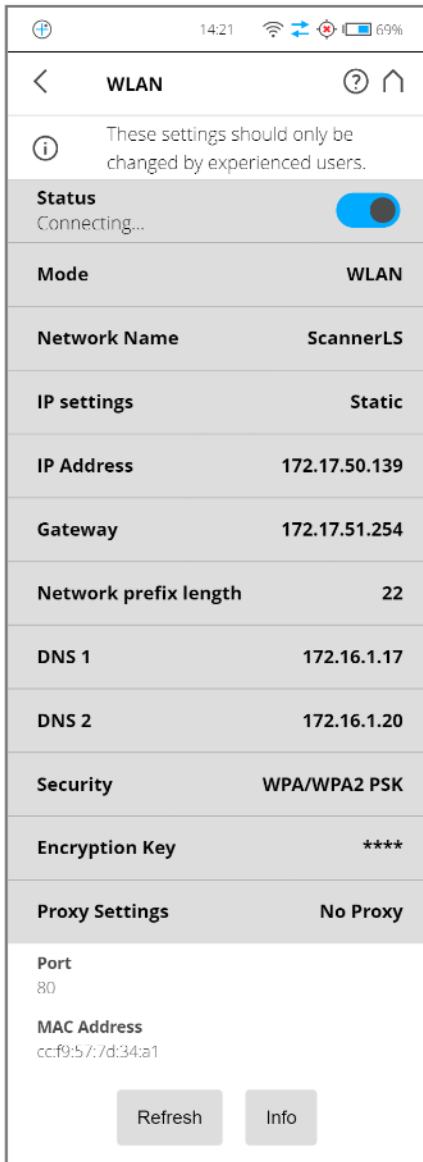

Figure 8-35 WLAN Settings

The scanner has an integrated WLAN module that remotely connects to the scanner with portable devices, such as notebooks, PDAs, or tablets. Connect your remote device to the scanner via WLAN, and remotely access the scanner user interface with a standard web browser. The WLAN option also provides remote access to the scan files on the scanner SD memory card.

It is possible to turn WLAN off from a remote interface. Since this might disable the connection to the remote interface, a warning is displayed.

NOTE: The scanner user-interface can be accessed through the following desktop browsers: Chrome, Mozilla Firefox, Safari, Opera, or Internet Explorer (Version 11). The WLAN option also provides remote access to the scan files on the inserted SD card if *Remote Access to Scans* is enabled on the General Settings page.

Mobile browsers: Android Chrome, Android Browser, and IOS Safari. WLAN settings can only be modified through the scanner user interface, and not with the remote interface.

Changes to the WLAN settings are only possible, if WLAN is turned off.

Status

Tap to turn this ON or OFF. Indicates whether or not WLAN is available. If WLAN is not needed, we recommend turning it off.

NOTE: Changes to the WLAN settings are only possible, if WLAN is turned off.

Two different WLAN operating modes are possible:

- **WLAN** - This setting is also known as infrastructure mode. The network is configured so that the scanner can connect to an external access point. Data transfer rates depend on the network and can reach 150 Mbit/s.
- **Access Point** - The scanner network is configured as an access point. The data transfer rate is limited to 54 Mbit/s.

WLAN Mode Scanner Settings

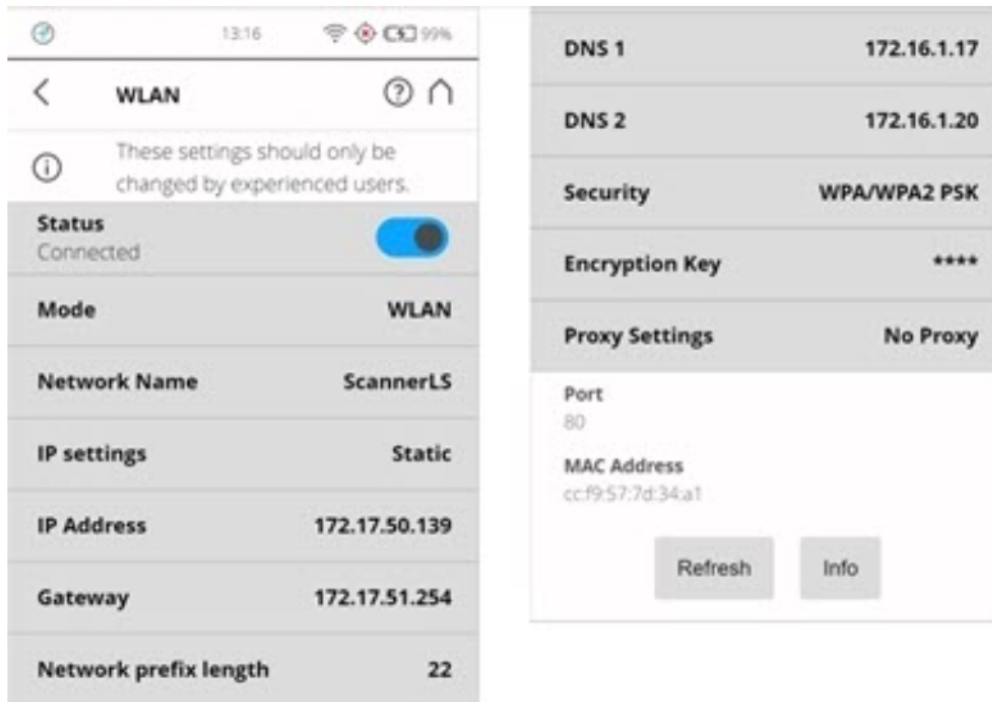

Figure 8-36 WLAN Mode

Network Name

The name of the wireless network. Tap it to enter a screen, where the available networks are displayed and can be selected.

IP Settings

Set a static IP Address, or obtain one automatically through DHCP.

The IP settings determine whether an IP address is assigned by a server using DHCP or manually set (Static):

- **DHCP**- This is the default/recommended setting.
- **Static**- The IP address is manually assigned. The following settings have to be provided.

IP Address

The IP address of the scanner. A unique IP address must be preset on the WLAN network. If your remote device is connected to the scanner, enter this address into the address field of your web browser (for example, <http://172.17.16.23>) to access the controller software. Tap to change the scanner's IP address.

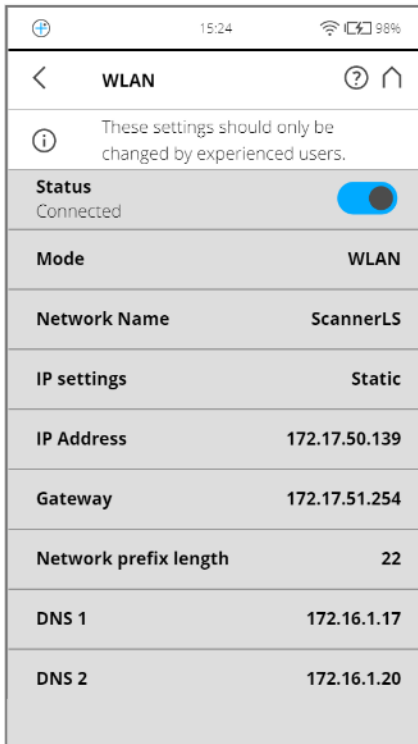

| WLAN | |
|---|-------------------------------------|
| These settings should only be changed by experienced users. | |
| Status Connected | <input checked="" type="checkbox"/> |
| Mode | WLAN |
| Network Name | ScannerLS |
| IP settings | Static |
| IP Address | 172.17.50.139 |
| Gateway | 172.17.51.254 |
| Network prefix length | 22 |
| DNS 1 | 172.16.1.17 |
| DNS 2 | 172.16.1.20 |

Figure 8-37 Connection to Scanner Interface through web browser

For secure, encrypted communication with the scanner GUI, enable the secure connection <https://172.17.16.23> in the address field of your web browser. You receive a security warning from the browser, before connecting to the GUI. Confirm to proceed.

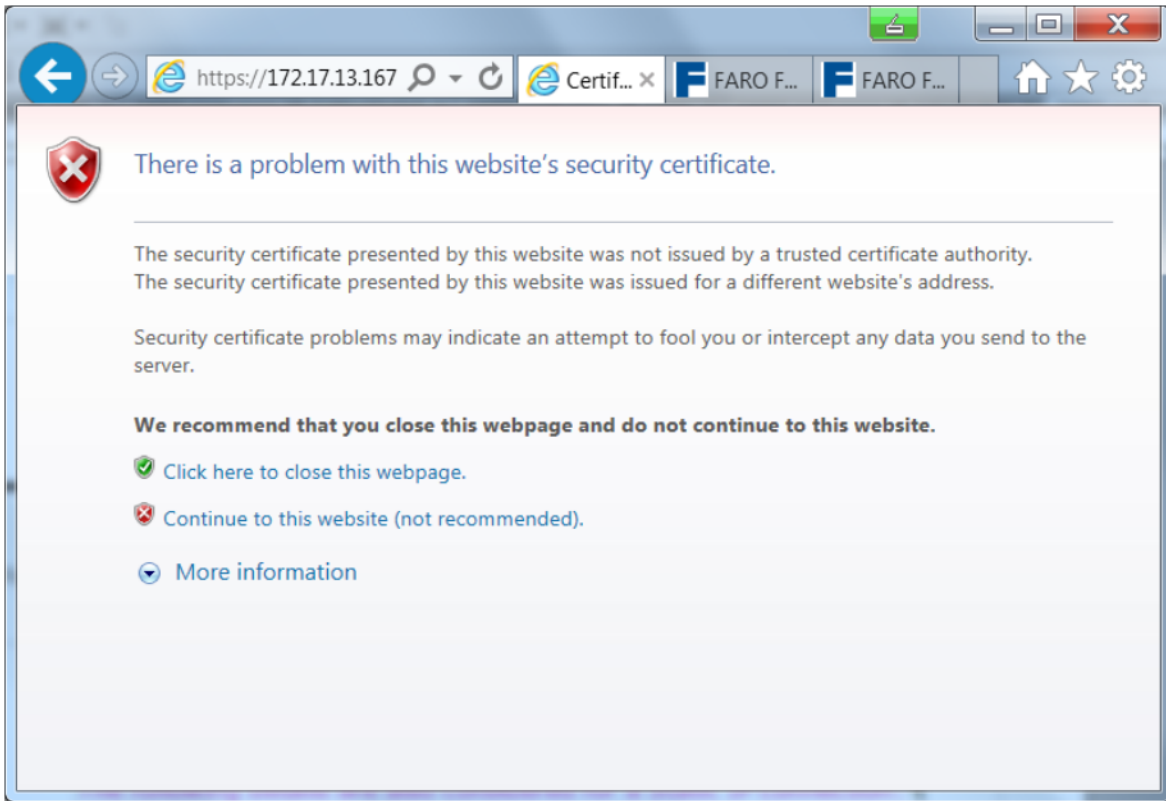

Figure 8-38 Scanner secure connection: Warning

Be aware that setting an IP address manually can result in a conflict, if two devices on the same wireless network claim to have the same IP address.

Consider the following for a Static IP connection:

Gateway - The gateway used to access the WLAN network.

Network prefix length - The subnet mask used in the WLAN network.

DNS 1 - First dynamic name server to be used in the WLAN network.

DNS 2 - Second dynamic name server to be used in the WLAN network.

Security - Choose the security protocol to be used by the access point to which the scanner connects:

- **Open** - Connect to an open network that can be accessed by anyone without a password. The information exchange is not secured.
- **WEP** - Connect to a network that is secured by WEP. This option requires an encryption key with 8 to 63 characters. This security level is not secure.
- **WPA** - First version of the WLAN Protected Access. Not recommended.
- **WPA2 PSK** - Connect to a network that is secured by WPA2. This option requires an encryption key with 8 to 63 characters. This is the default and recommended option.

Encryption Key

The scanner network is encrypted with a WPA2 key. Enter this key on your remote device, when prompted to establish the connection. If you want to change the encryption key, tap the corresponding button, then enter your own key. The key must consist of 10 to 63 arbitrary digits.

Proxy Settings

Settings related to connection through a proxy.

- **No Proxy** - Don't use a proxy. Choose this option, if the network that the scanner connects to has direct Internet access.
- **Manual** - Use a manually-configured proxy. Configuration includes:
 - **Host** - The host name (or IP address) of the proxy server.
 - **Port** - The port through which to connect to the proxy server.
 - **Exclusion List** - A comma-separated list of hosts for which no proxy is used.
 - **User Name** - The user name used to log-in to the proxy server (if required).
 - **Password** - The password used to log-in to the proxy server (if required).

Refresh

Tap to refresh the WLAN settings displayed in this screen.

Reset

Tap to reset the WLAN settings to their factory default.

If a connection cannot be established, the status immediately turns off after the message *Enabling* is displayed. Check the Network Name and the Encryption Key, when a connection in WLAN mode must be established.

Access Point Mode Settings

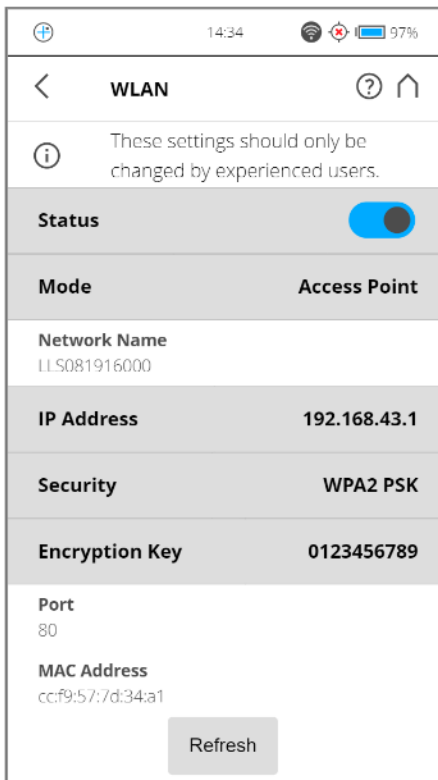

Figure 8-39 Access Point Mode Settings

The following section describes the additional or special settings for the access point mode.

Network Name

The name of the network that the scanner creates. The scanner serial number is used as the Network Name. Your remote device displays the scanner with this name in the list of the wireless connections. If the scanner is not listed, refresh the network list. After a few seconds the remote device finds the scanner and displays it in the list.

Scanner IP Address

The IP Address of the scanner is set. Use this IP to access the remote user interface.

Update

Tap to update the displayed settings. This might be necessary, if a connection is lost, because the scanner was out of range, for example.

Example Configuration of a Notebook with MicrosoftWindows

Connecting the scanner

1. Click the wireless network button on the bottom right of the task bar. A list with the available wireless network connections appears.
2. Select the scanner network in this list. The scanner is listed with the above mentioned network name.

3. Click **Connect**.
4. When prompted, enter the WLAN encryption key.

Notebooks in Ad Hoc Mode

For the WLAN running in ad hoc mode, assign a static IP address to your notebook.

- Open Control Panel > Network and Internet > Network and Sharing Center.



Set up a new connection or network

Set up a wireless, broadband, dial-up, ad hoc, or VPN connection; or set up a router or access point.



Set up a wireless ad hoc (computer-to-computer) network

Set up a temporary network for sharing files or an Internet connection.

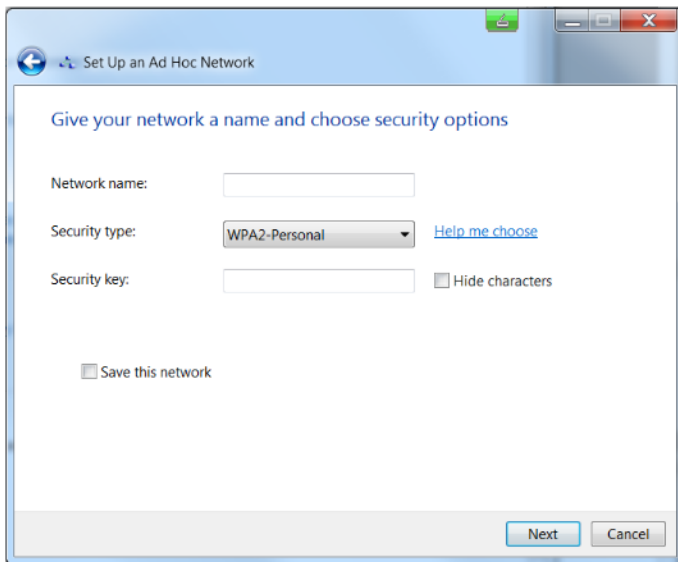

In the Internet Protocol dialog, choose **Use the following IP address**. Enter a valid IP address and sub-net mask. The IP address and sub-net mask of your notebook must be compatible with the scanner's. Change the last number of the scanner's IP address and use the address. For example, if the scanner has 172.17.16.23, you can enter 172.17.16.100. The sub-net mask must be identical to the scanner's. You may have to disconnect and re-connect to get the connection to work.

Open User Interface in the Web Browser

- With the notebook connected to the scanner, open your web browser.
- In the web browser's address field, enter the scanner's WLAN IP address to access the controller software. For example, `http://172.17.16.23` or `https://172.17.16.23` for a secure connection.
- The **Home** screen of the controller software appears in your web browser, allowing you to control the scanner.

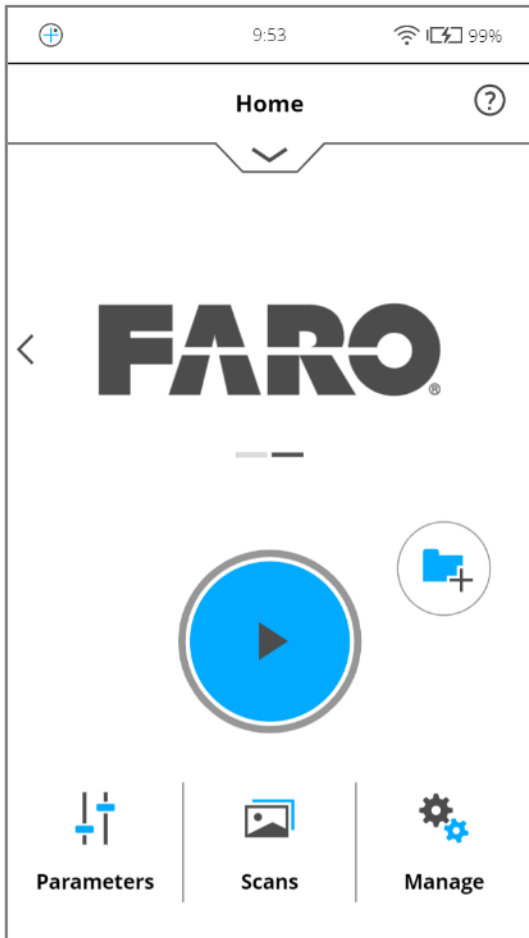

Figure 8-40 Controller software in web browser of a remote device

Remotely Accessing Scans on the SD Card

To access the scan files that are stored on the scanner's removable SD card from a connected remote device, enable remote access in the scanner's controller software.

1. Tap [Frequently Used Buttons on page 55](#) > [Manage on page 66](#) > [General Settings on page 85](#).
2. Open a file explorer on your remote device, such as Windows Explorer, then enter the **ftp://WLAN_IP_ADDRESS_OF_SCANNER/Scans** into the address bar. For example, **ftp://172.17.16.23/Scans**.
3. You can download the scans to your remote device via file operations. Note that copying files from the scanner through WLAN can take considerable time. How long this takes depends on the connection speed and signal strength.

Scanner Details

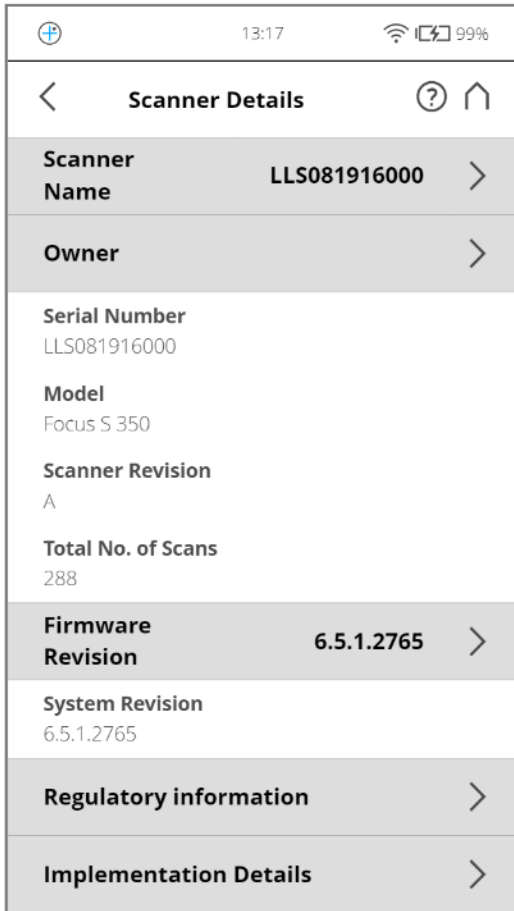

Figure 8-41 Scanner Details

Scanner Name - Name the scanner.

Owner - Enter the owner of the scanner.

LAN IP Address -The Ethernet IP address of the scanner.

Subnet Mask -The Ethernet subnet mask of the scanner.

Serial Number - Serial number of the scanner. This number is unique for each scanner.

Model - The scanner type.

Total No. of Scans - The total number of scans captured with this scanner.

Firmware Revision / System Revision - The revisions of the currently installed firmware and system software.

On-Site Registration

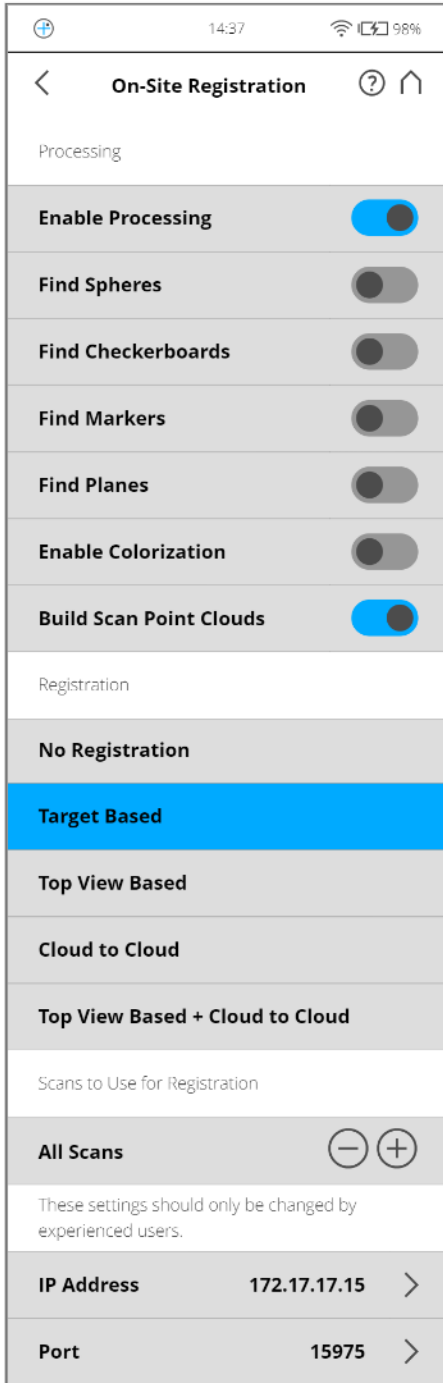

Figure 8-42 On-Site Registration Settings

This page displays the available settings for uploading, processing, and registering scans in a connected SCENE instance.

All uploaded scans are continuously processed and registered according to the settings below.

See the **Processing** and **Registration** chapters in SCENE manual for details regarding the processing- and registration-related settings.

Enable Processing: This contains settings that define important processing options that can be run remotely on SCENE after the scans have been uploaded.

Find Spheres: Slide to turn-on. This automatically detects spheres in the uploaded scans. Use this setting, if you use spheres as external targets for a target-based registration.

Find Checkerboards: Turn-on to automatically detect checkerboards in the uploaded scans. Select this setting, if you use checkerboards as external targets for a target-based registration.

Find Markers: Turn-on to automatically detect markers in the uploaded scans. Select this setting, if you use markers as external targets for a target-based registration.

Find Planes: Turn-on to automatically detect planes in the uploaded scans. This setting can improve a target-based registration.

Enable Colorization: Turn-on to enable the colorization of the uploaded scans.

Build Scan Point Clouds: Turn-on to build a point cloud from the uploaded scans. Scan point clouds facilitate a fast visualization of scan points.

Registration

Determine the method used to align and join the uploaded scans to each other in SCENE.

No Registration: Select this to skip the registration step.

Target Based: Use this to perform a target-based registration for the uploaded scans. The target-based registration uses targets to place the scans. These could be natural or artificial targets, or example, spheres, checkerboards. Enable the corresponding settings in the Enable Processing section for this type of registration.

Top View Based

Perform a top-view-based registration. This method is sufficient in most cases, and does not require additional targets.

Cloud-to-Cloud: Perform a cloud-to-cloud registration. This can refine the registration of scans. It can be very time consuming.

Top View Based plus Cloud-to-Cloud: Perform a top-view-based registration followed by a cloud-to-cloud registration.

Network Settings

The IP address and port settings define the network address of the computer running SCENE.

IP Address: The IP address of the computer running SCENE is automatically updated.

Port: The port number of the computer' running SCENE is automatically updated.

Service

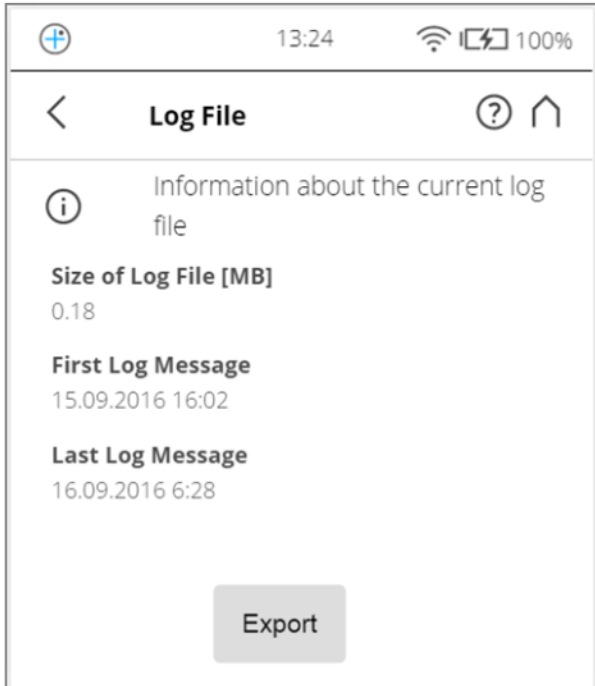

Figure 8-43 Service

Errors & Warnings - Tap Notifications in the navigation bar to view warnings and other status messages. This is not enabled, if there are no warnings or errors. See [Errors and Warnings on the next page](#)

SD Card - View details about the currently inserted SD card or format the SD card. See [SD Card on page 103](#)

Log file - Export the log file to the SD card. See [Log File on page 104](#)

Backup - Backup scan profiles, operators, color themes, and scanner parameters as scanner snapshots to the SD card. See [Backup on page 104](#).

Restore - Restore scan profiles, operators, color themes, and scanner parameters from scanner snapshots, or restore scanner snapshots that have been created with SCENE. See [Restore on page 105](#)

Firmware update - Update the scanner with new firmware versions. See [Firmware Update on page 107](#)

Factory Settings - Reset the scanner to its factory settings. See [Factory Settings on page 108](#).

FARO Customer Support - View the FARO Customer Support contact data.

Command Prompt - Send commands to the scanner. This function is for FARO Service purposes only.

Last Service Date - Date of the last scanner maintenance and certification service.

Errors and Warnings

Provides a list of current warnings and errors. Tap a listed item to view details of the corresponding warning or error.

Warnings and errors disappear from the list once they are resolved.

NOTE: If an empty or full SD card is inserted, the LED turns red and a permanent notification is displayed. Even after the SD card is removed, both warnings remain active until the scanner is shut-down.

Shows a description of the warning or error, providing a possible solution to the problem.

Warning ID / Error ID - The identification number of the warning or error.

Description - A detailed description of the warning or error.

Possible solution - The notifications consist of an ID followed by a detailed description of the warning or error, as well as a possible solution.

SD Card

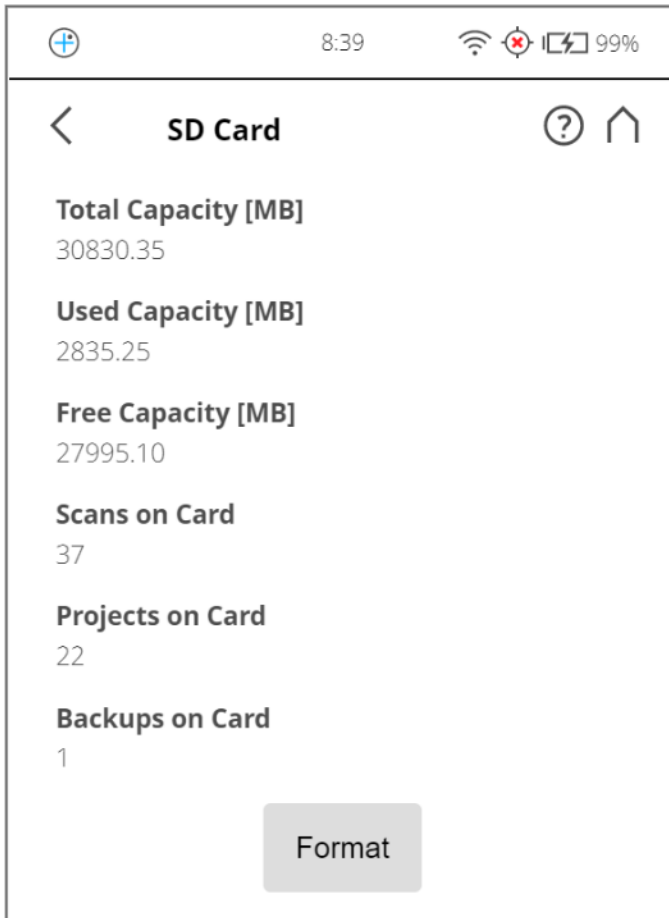

Figure 8-44 Service, SD Card

Provides information regarding the currently-inserted SD card and its contents.

Format Card - Format the inserted SD card.

NOTICE: Format the inserted SD card.

This operation deletes all scans and other data on the SD card. Always use this formatting function for SDXC cards with a capacity of 64 GB or more, because Windows formats such cards with its own file system, which is not supported by the scanner. See [Preparing an SD Card on page 29](#).

Log File

Important scanner operations, sensor data, as well as warnings and errors, are saved to the log file to help customer service identify problems and their possible causes.

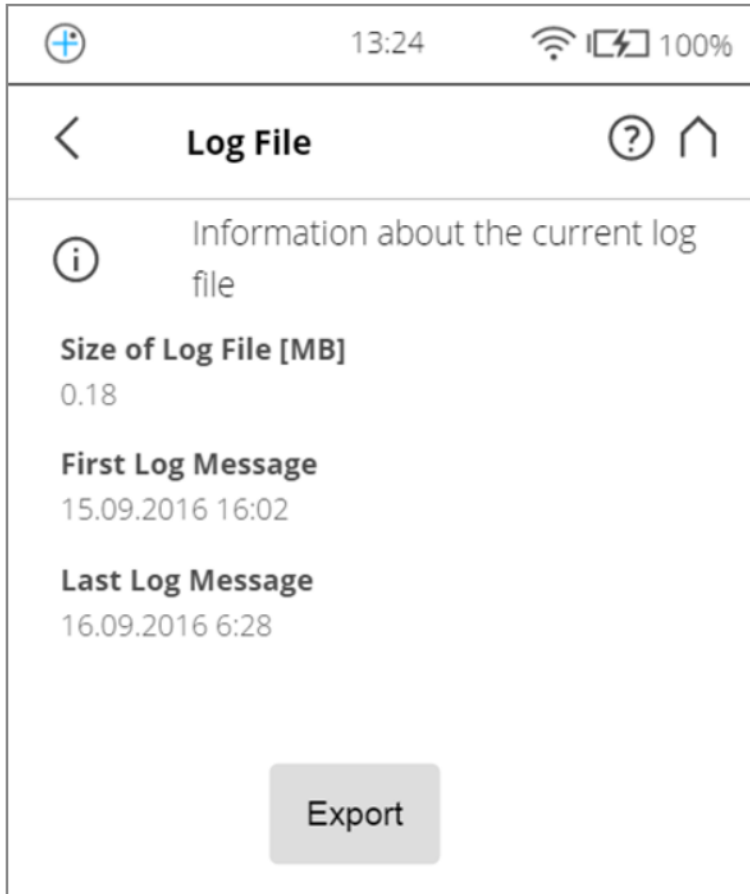

Figure 8-45 Service, Log File

Export - Writes the scanner log file to the SD card. It is saved in a folder called *Logfile*.

Backup

Automatic Backup

The scanner creates an automatic back-up of the scanner settings, and saves it to the inserted SD card. This back-up is automatically updated with the current scanner settings each time you start a scan. It includes the current scan profiles, scanning parameters, operators, and general settings.

Manual Backup

Create manual back-ups of certain scanner settings. This saves scanner parameters, operators, and scan profiles to the SD card.

The manual back-up option creates snapshots of this scanner data to help protect from accidental loss, if your scanner hardware or storage media fails. It creates a duplicate of the data on the SD card. You can then archive the data on another storage device, or modify it with SCENE, transferring the modified data back to your scanner.

If you own more than one scanner, you can also transfer operators and scan profiles from one scanner to another without manually re-entering the data.

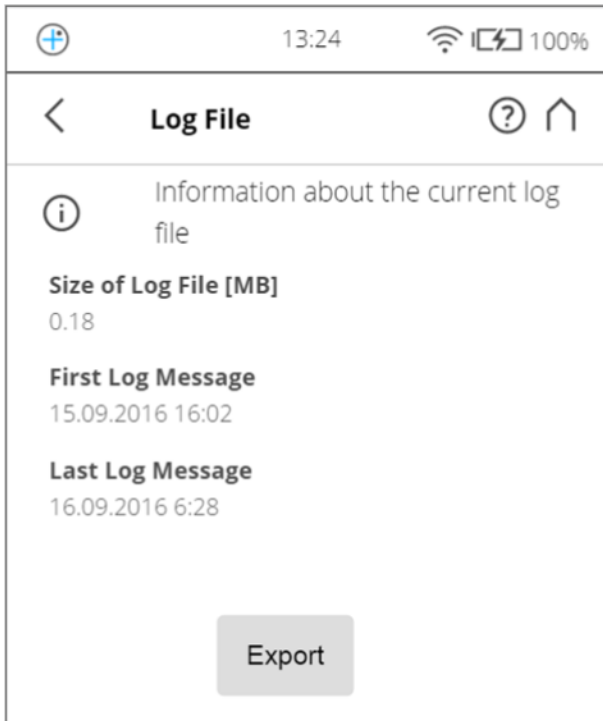

Figure 8-46 Service, Backup

Backup Name - Tap to enter the name of the back-up package. Data is saved to the following directory on your SD card: **/Backup/Your_backup_name/**.

After specifying the name of the back-up folder, select the data to back-up, then tap **Backup** to start the operation.

Restore

With this function you can:

- restore operators, scan profiles, scanner parameters, and wallpaper from archived back-ups or scanner snapshots.
- import operators, profiles, and wallpaper that were newly created with SCENE.
- import formerly backed up operators, profiles, and wallpaper that were modified with SCENE.
- import operators, profiles, wallpaper, and scanner parameters from other scanners.

NOTE: The number behind **Operators** and **Profiles** denotes the number of operators, scan profiles, and wallpaper files on the scanner.

To restore data, it must be saved to an SD card. Create a directory on the SD card called *Back-up*, then copy the folder, along with the data to be restored, into this directory. If you use SCENE to create or modify backed up data, this is automatically done by SCENE.

When finished, insert the SD card with the data to be restored.

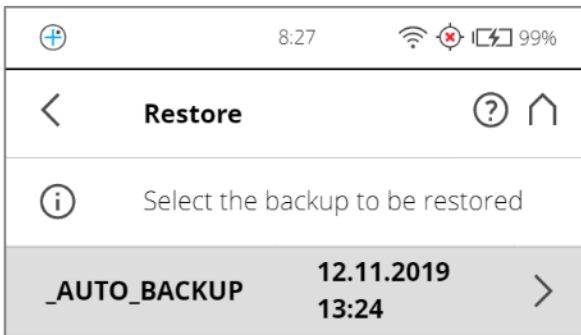

Figure 8-47 Service, Restore - Select Backup File

List all back-up packages on the inserted SD card. **_AUTO_BACKUP** is the automatically-generated scanner snapshot (see [Backup on page 104](#)). **_SCENE_BACKUP** is the scanner snapshot that was created or modified using SCENE. Tap the back-up package to be restored. A new screen appears.

Select the data from the back-up package to be restored, then tap **Restore** to start the restoration process.

CAUTION: The restored data overrides existing data on the scanner.

For example, if you want to restore or import scan profiles, all existing scan profiles on the scanner are overridden by the new profiles. The scanner's default profiles remain unaffected by this operation. **FARO recommends backing up your data before restoring.**

Firmware Update



Figure 8-48 Service, Firmware Update

There are two ways to update the firmware of your FARO Laser Scanner:

- The scanner is online and can fetch the firmware from a server.
- The firmware is transferred using an SD card.

The update process can take up to 30 or 40 minutes, depending on the size of the update. The scanner must be connected to power and have a fully-charged battery to begin the firmware update.

Switch **Fast Installation** on to make installation faster and safer by not updating scanner modules that already have the required version. Disable this option to force updating of all modules. Disabling leads to longer installation times and can increase the risk of unrecoverable failures. We recommend that you keep fast installation enabled.

Online Updates

Enable *Online Updates*. Slide this button to turn it ON or OFF

Select **Set Update Server URL** to set the URL link of the server that provides the online firmware updates.

Tap **Search for Updates Now** to search for firmware updates online.

Update via SD Card

If you have the firmware update file on your computer, you can use the SD card to transfer it to the scanner. Copy the update file to the folder “**Updates**” on your SD card. If this folder does not exist, manually create it. Pay attention to lower and uppercase, when entering the folder name. Insert the SD card into the scanner, and tap **Update from SD Card**.

CAUTION: Risk of data loss and non-functional device!

DO NOT manually shut-down, reset or power-off the scanner during the firmware update process! Any interruption of the firmware update process can result in corruption of the system and making the device inoperable.

After the update is complete, the scanner might automatically restart, depending on the nature of the updates.

Factory Settings

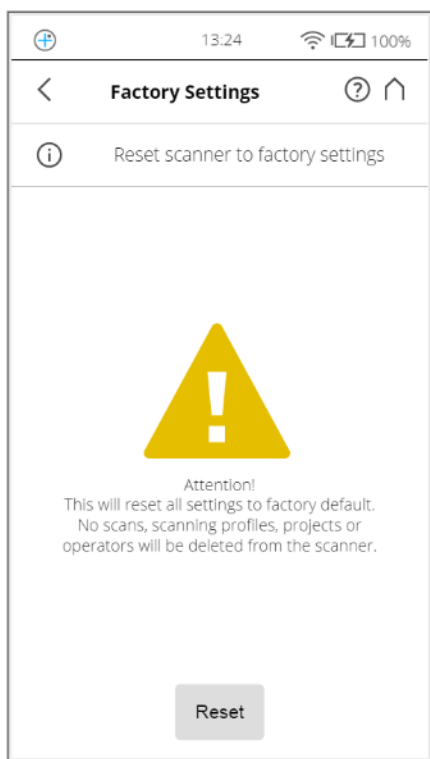

Figure 8-49 Service, Reset to Factory Settings

NOTICE: This function resets your scanner settings to factory default. Use this only in exceptional cases.

The scans, scan profiles, scan projects, and operators saved on the scanner are unaffected by this operation.

View Scans

View previews of the scans stored on the inserted SD card. A list of all available scans is displayed:



Figure 8-50 Scans List

This list contains all scans available on the SD card. The list is sorted by the scans' date-of-creation.

Tap a scan in the list to see its preview picture.

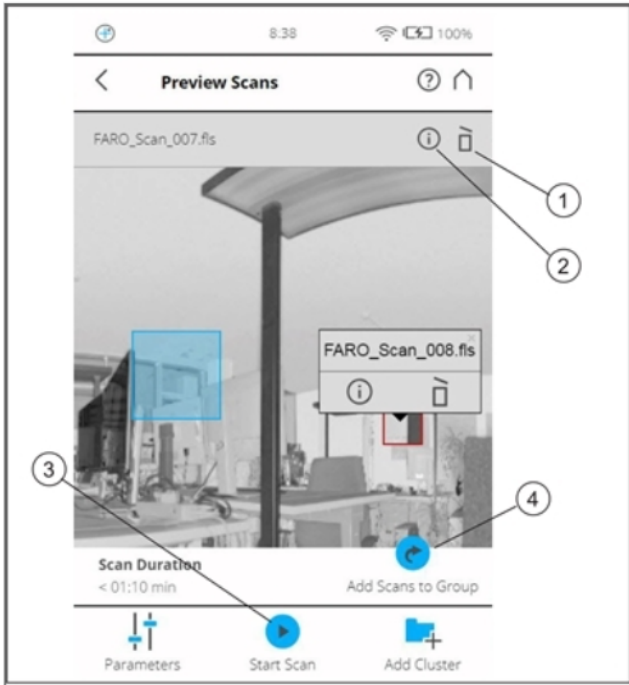



Figure 8-51 Preview of a Scan/Scan Group

- ❶ **Delete** - Deletes the currently displayed scan from the SD card.
- ❷ **Info** - Tap to view the scan properties.
- ❸ **Start Scan** - Starts a scan, or resumes the previous scan.
- ❹ **Add Scans to Group** - Adds a new detail scan to the group.

For scan groups, the detail scans are shown together with the primary scan. Zoom-in using a pinching gesture, or the mouse wheel, to enlarge the detail scan's preview. Tap or click the detail scan to display a pop-up window with the name of the detail scan, a link to the related Scan Properties page, and the option to delete the detail scan.

Online Help and Notifications

Notifications

Tap **Notifications**  in the navigation bar to receive warnings and other status messages. The button is not enabled, if there are no warnings or errors.

Help

Open a description of the currently-displayed view by tapping **Help**  in the navigation bar.

The online help provides useful information regarding the currently active view.

Chapter 9: Special Scanning Modes

In combination with an external computer, some special scanning modes are available:

- On-Site Registration
- On-Site Compensation

The external computer must run SCENE, and be connected to the FARO Laser Scanner via WLAN.

By default, SCENE is not configured to offer these modes in the Workflow Bar. To use them, activate the Scanning category in the settings under **Settings > General > User Interface > Show Scanning Category**.

In addition to On-Site Registration and On-Site Compensation, the Scanning category also offers control of the scanner using SCENE.



Figure 9-1 Scanning toolbar

Scanner Control

To connect to the scanner:

1. Enter the scanner's IP address.

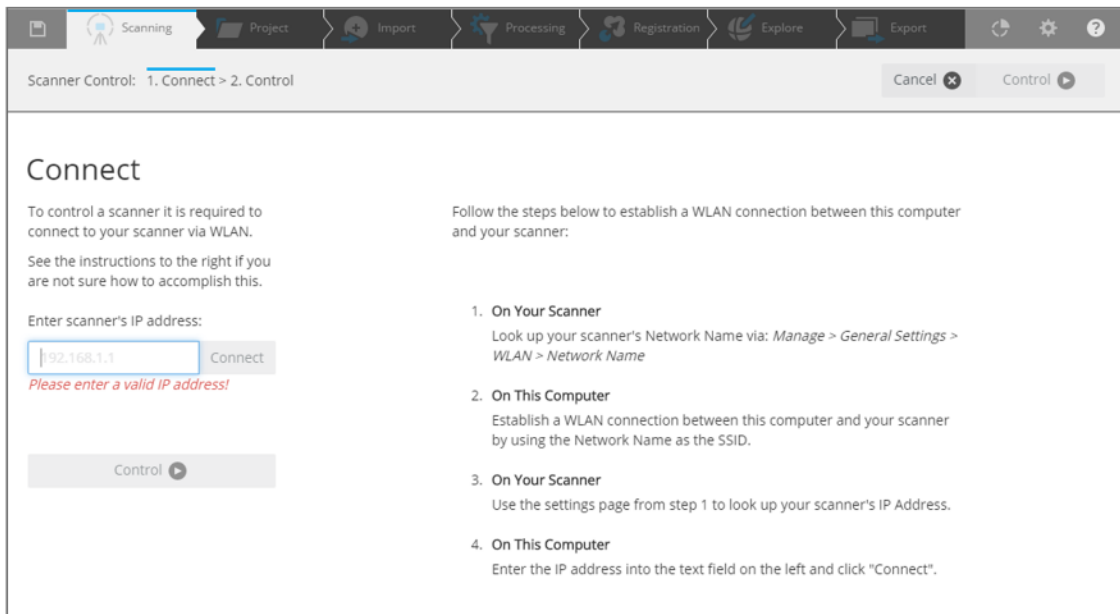

Figure 9-2 Connect page: Enter the IP address

2. Click **Connect** to retrieve the details of the scanner.

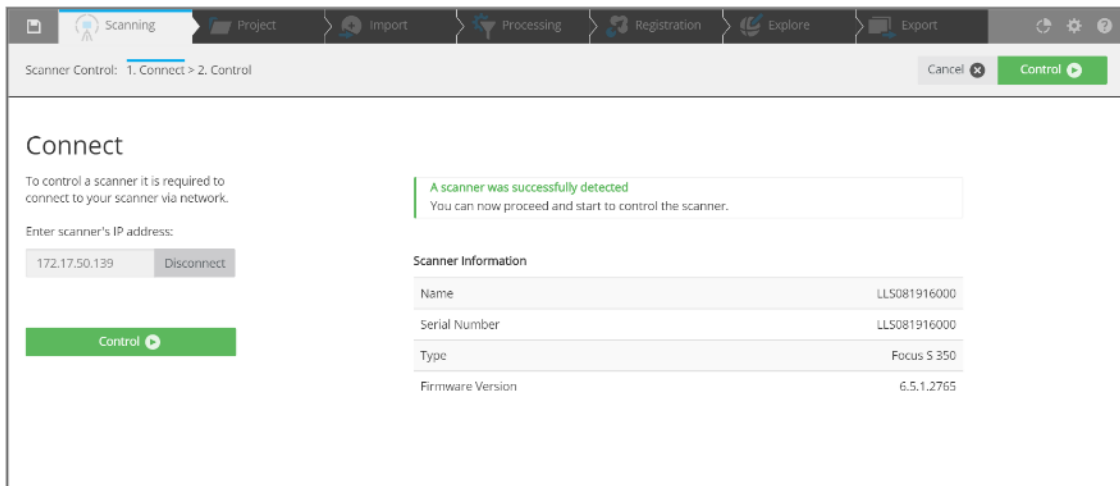

Figure 9-3 Connect to Scanner

3. If the IP address is not associated with an active laser scanner, an error message is displayed.

4. If a connection to a supported FARO Laser Scanner is successful, **Control** is active and green. Click to control the scanner through the HTML user interface.

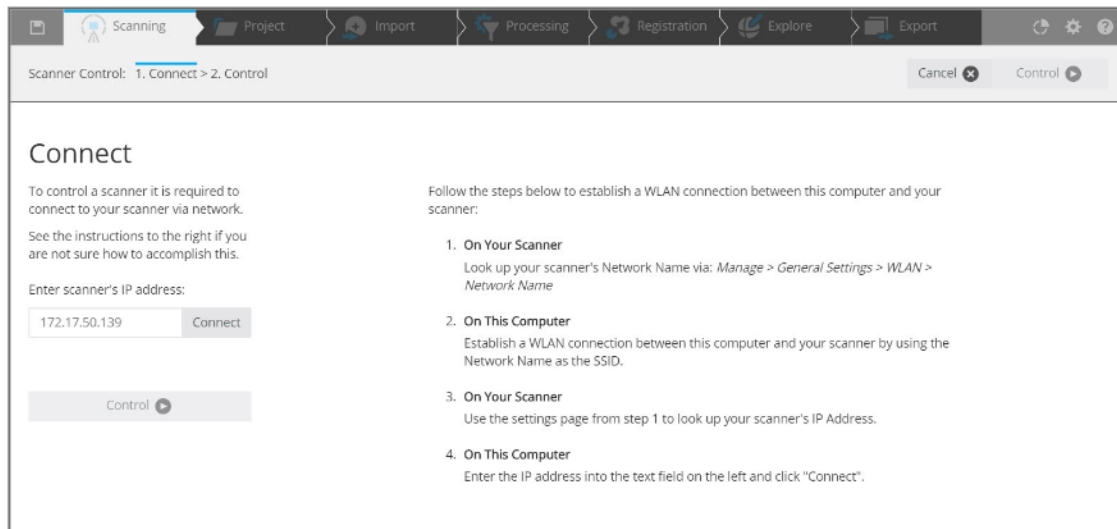

Figure 9-4 Click to Control the Scanner

5. SCENE starts the **Scanner Control** task, then displays the scanner user interface. You can control the scanner remotely through this HTML interface.

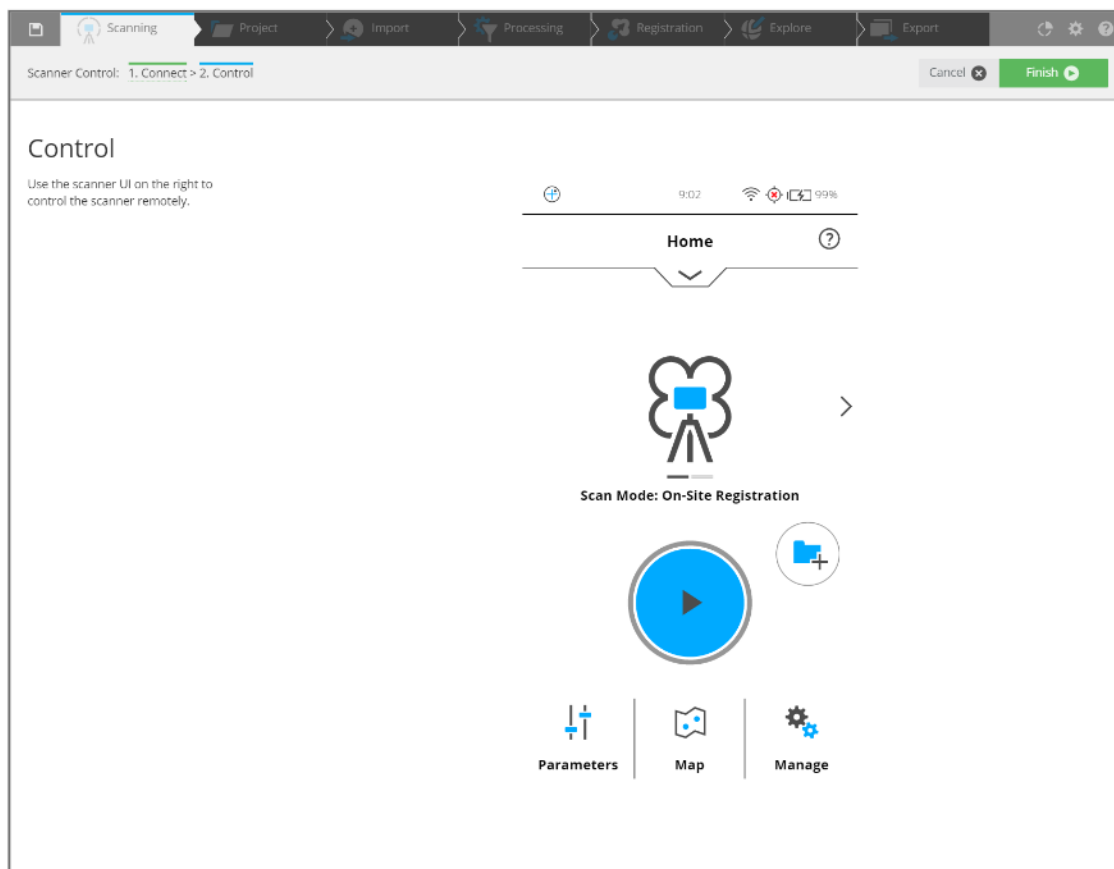

Figure 9-5 Finish or Cancel task

6. Click **Finish** or **Cancel** to close the scanner user interface, scanner control task, and disconnect from the scanner.

On-Site Registration

The On-Site Registration feature enables you to process and register scans while on-site. The scanner must be connected to a computer running SCENE, because processing and registration of the scans are performed in SCENE.

After the initial setup, you can perform On-Site Registration in one of the following ways:

- directly on the scanner,
- through a connected device, such as a phone or tablet, showing the scanner user interface,
- or in SCENE

NOTE: On-Site Registration is not available on all scanner models. See [Introduction on page 2](#)

On-Site Registration Setup

Use the procedure below to set-up on-site registration on the scanner:

Configure the Scanner

1. Configure the WLAN connection on the laser scanner. See [WLAN on page 88](#).
2. Configure the scan project, scan cluster, scan name, or scan parameters.

Use the procedure below to set-up on-site registration on the scanner using your computer:

Configure Using SCENE

1. Configure the WLAN network of the computer.

NOTE: The scanner and computer must be continuously connected to the same WLAN network.

2. Start SCENE on the computer.
3. Start **On-Site Registration** task under **Scanning** in SCENE.
4. Enter the IP address of the laser scanner. Find the IP address by tapping **Manage > General Settings > WLAN > IP Address** on the scanner user interface. Enter the IP address exactly as shown.
5. Connect to the FARO Laser Scanner.
6. Click the left or right arrow (or swipe), until the home screen changes to **On-Site Registration** scan mode.

NOTE: The buttons available at the bottom of the screen change; instead of **Scans**, **Map** appears.

7. Click **Manage > On-Site Registration** to change on-site registration-specific settings. Consider the following:
 - **Enable Processing** - Enable Processing to find spheres, checkerboards, markers, planes, to enable colorization, or to build the scan point cloud. Disable all scan processing during On-Site

Registration to save time and computing power. The scans can be processed later, off-site.

- **Registration** - Choose a registration type. The registration settings determine the method used to align the uploaded scans to each other in SCENE. Refer to the SCENE user manual for detailed information regarding different registration methods. Ensure that processing and the relevant marker detection is enabled, when using target-based registration.
- **Scans to Use for Registration** - Set the number of scans to use for registration. (SCENE first tries to register a new scan using the most recent previous scan. If this registration attempt fails, SCENE tries to register it using the scan immediately before the last scan, and so on. If you make a new scan that has no connection to any previous scan, SCENE attempts to register the new scan with all the scans in the project, one after the other, as previously described. This can be time consuming, if there are a lot of scans in the project. In such cases, consider lowering the number of scans to be used for registration.**IP Address and Port:** - Manually enter the IP address of the computer running the SCENE instance.

NOTE: These settings are automatically set by SCENE, and should only be changed by experienced users, who have a specific reason to change them.

8. On the scanner home page, click **Map**. A map is displayed with the available scans in a project.

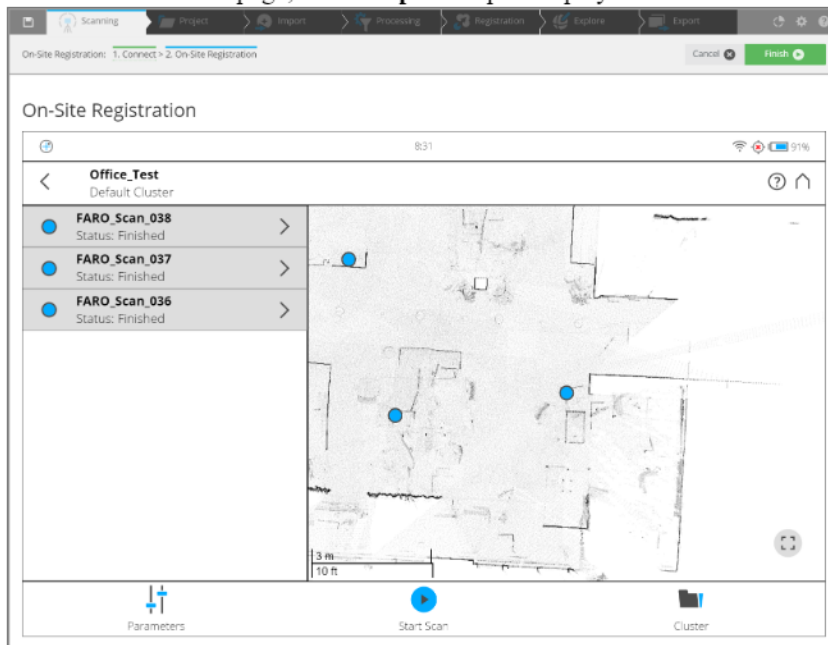

Figure 9-6 On-Site Registration overview map with list and status of scans

9. Click **Start Scan** to start a new scan on your scanner, or remotely in SCENE. All recorded scans on the current cluster or project opened on the scanner are uploaded to SCENE. The scans are then automatically processed by SCENE.

NOTE: If one scan fails to register, run a connection scan with the scanner placed between the area of the two different scans. To validate the registration of scans, highlight their points on the map. For more details, refer to [Registration](#).

Map Page

This shows an overview of the area that has been scanned.

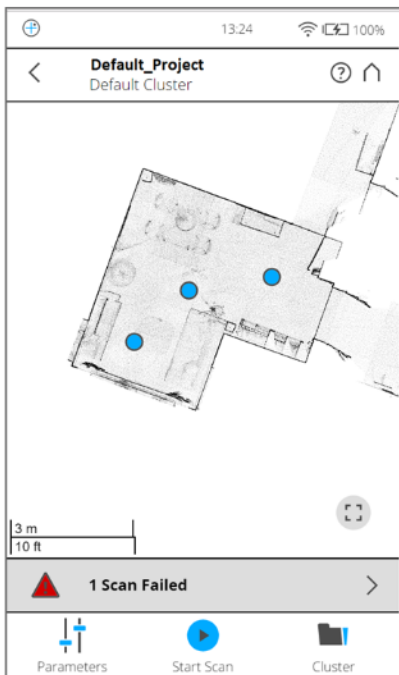

Figure 9-7 Map page

Overview Map

Display a map of a top-down view of all scans in the current cluster or project that have been successfully registered. Scan positions are shown by blue markers. Click a marker to highlight the points of a scan in the map. A small pop-up menu opens displaying the name of the scan. Tap the scan point on the map to open the **Scan Details** page. Tap the button in the lower right corner of the map to reset the view, so that all markers are visible.

Status Bar

The status bar is shown below the overview map.

On large screens, the list of scans with their processing status is shown to the left of the map. On small screens, the list can be accessed by clicking the status bar below the map. It displays the most important information. The following messages may appear:

- '# of scans' failed: One or more of the following failed: Scanning, processing, scan import, or registration.
- '# of scans' scans in progress.
- '# of scans' scans finished.
- '# of scans' unknown: Scans have been initiated on the scanner and their completion status is not known.

Click the status bar to switch to the list page. For details, see [List Page below](#).

Scan Controls

At the bottom of the screen, three scan controls are available:

- **Parameters** - View the Parameters page.
- **Start Scan** - Start a scan.
- **Cluster** - Switch to project or cluster selection.

List Page

This shows a list of all scans in the current cluster or project. On large screens, the list is shown to the left of the map. On small screens, the list can be accessed by clicking the status bar below the map. The on-site registration status of each scan is shown on the left. Tap the right arrow to view the [Scan Details page](#) for the specific scan.

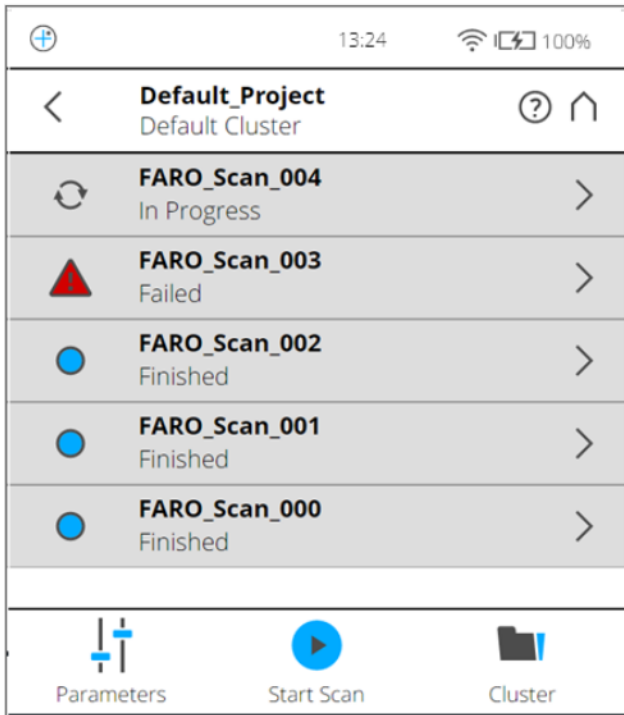





Figure 9-8 List Page

Each list item for a scan contains the following information:

The status indicator displays the scan name and status of the scan as follows:

- Processing:  - The scan is being processed.
- Registration Successful:  - The scan is completed.
- Registration Failed:  - The scan registration failed.
- Waiting for Processing - The scan must be processed.
- Status Unknown  - The scan is initiated, but the status is unknown.

Tap the arrow to the right of the scans to go to the [Scan Details Page](#) below for further actions on the particular scan.

Scan Details Page

This shows detailed information for a single scan.

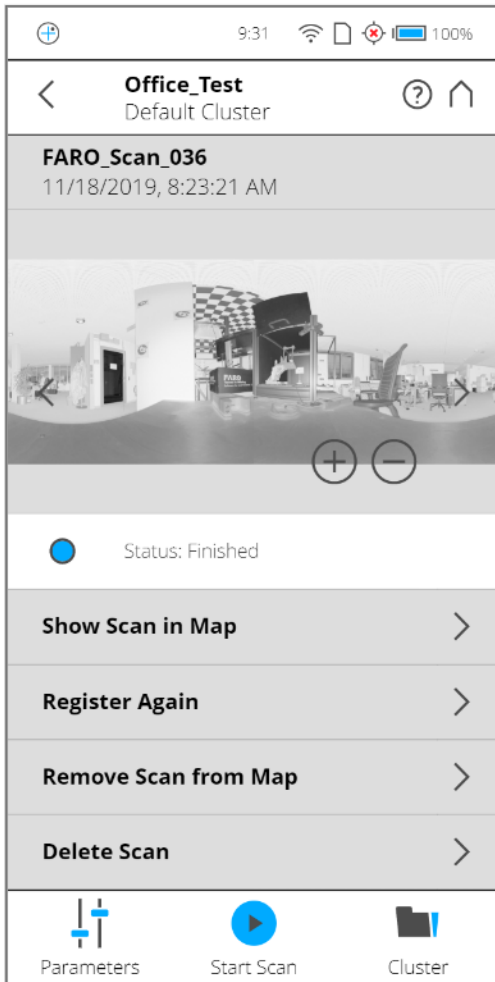

Figure 9-9 Scan Details Page

Preview image - The preview image of the scan. As with the preview page, switch current scans by clicking the arrows to the left and right of the preview image.

Status bar - Displays the information about the on-site registration status of the scan.

List of actions - Lists the different actions that can be performed on the scan, depending on the status of the scan. These are listed below the status bar.

NOTE: If it is impossible to perform an action, the listed item is grayed out.

Possible actions:

Show Scan in Map

This option is only available for finished scans. Tap the right arrow to view the map page. The view centers on the selected scan, and it is marked in the map.

Register Again

This option is available for scans that either succeeded or failed in registering.

A dialog pops up when you tap the right arrow. Tap **Confirm** to re-register the scan. The scan is being re-registered, and the registration status is displayed as **Unknown** until the process is completed.

Remove Scan from Map

This option is available for scans shown in the map that were successfully registered.

A dialog pops up when you tap the right arrow. Use **Confirm** to remove the scan from map. Although the scan is removed from the map, it is not deleted. The scan status is **Registration Failed** after it is removed from the map.

Delete Scan

This option is only available for scans that are not **In Progress**.

Tap the right arrow to view the **Delete scan** dialog. Use **Confirm** to delete the scan.

CAUTION: The scan is deleted from the cluster or project.

On-Site Compensation

This tests and improves the angular accuracy of the scanner using SCENE.

NOTE: On-Site Compensation is not available on all scanner models. See [Introduction on page 2](#)

Preparing the Compensation Station

Site Setup

Before you begin the On-Site Compensation process, ensure that the scan site has the following facilities:

- Target sheets must be set-up at the scan site at regular distances in relation to the laser scanners; between 1.5 m to 3 m.
- No windows or other reflective planes should be in evidence. The markers on the target sheets are reflected, if the scan site has any reflective surfaces. This can cause incorrect measurements.
- Lighting conditions are less important, because On-Site Compensation is done with the laser, therefore video images are not used.

Connect Laser Scanner to Computer through Wireless LAN

To transfer the scanned data directly to your computer, you must connect the computer with the laser scanner, through WLAN, to remotely access and control the scanner.

Using the Scanner as a WLAN Access Point

NOTE: Disable the proxy server to make the connection work. If this is not possible for some reason, enter the addresses of both devices in the Exceptions field. We recommend to use a WLAN card that supports IEEE 802.11n.

On your Scanner

1. Enable the WLAN on the scanner (see [WLAN on page 88](#)).
2. Look-up your scanner's network name by tapping **Manage > General Settings > WLAN > Network Name** on the scanner's user interface.



On your Computer

Establish a WLAN connection between the computer or tablet, and the scanner, by using the network name as the SSID.

On-Site Compensation Steps

On your computer:

Select Output Folder

1. Click the **Start On-Site Compensation** button  in the scanning toolbar.
2. All data captured during On-Site Compensation, including the **Compensation Report**, is stored in the output folder.
3. Click the **Browse** button  to open the file system browser.
4. Browse to the folder. Click **OK**.

Setup

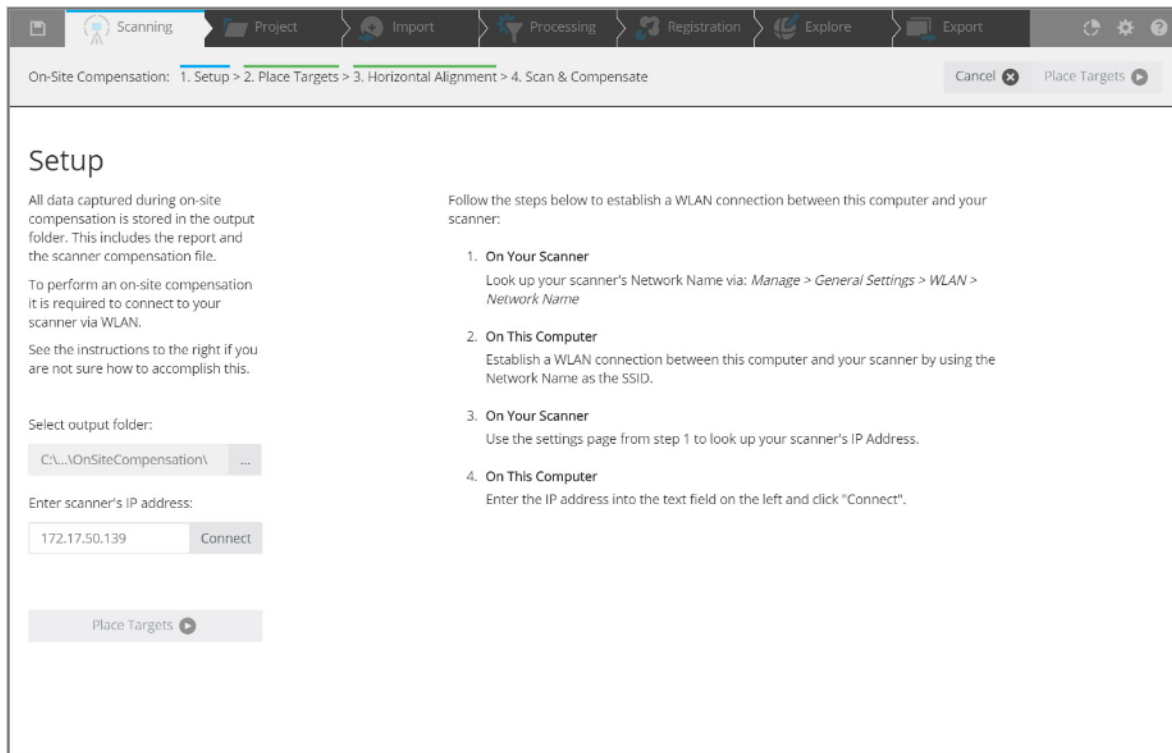

Figure 9-10 Setup: Select Output Folder and Enter IP Address

Enter Scanner IP Address

1. Enter the laser scanner's IP address. Find the IP address by tapping **Manage > General Settings > WLAN > IP Address** on the scanner user interface. Enter the IP address exactly as shown.

2. Click **Connect**.
3. In the dialog, click **Place Targets** to continue to the next step.

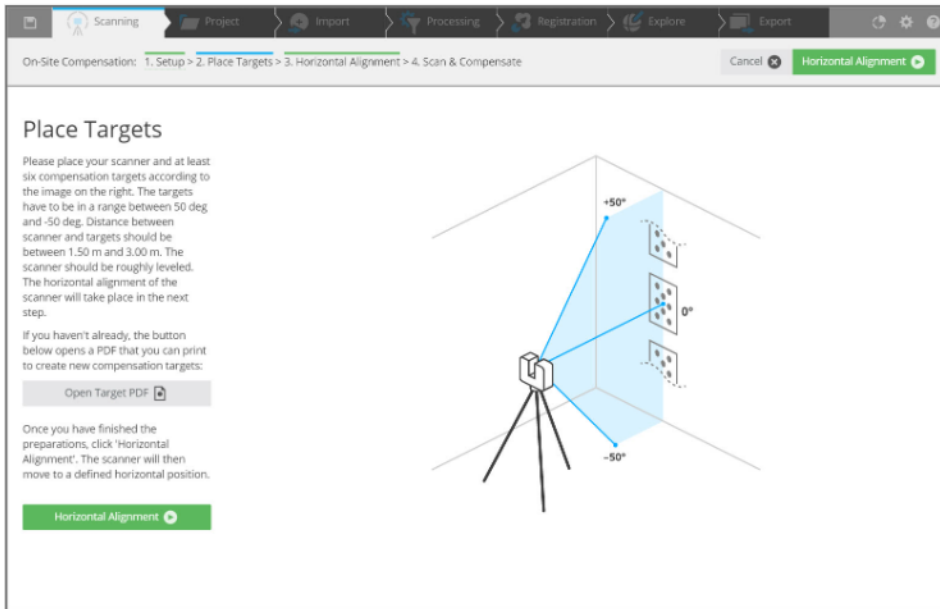

Figure 9-11 Place Targets

Place target

Print Target Sheets

NOTE: With SCENE 2021, the on-site compensation scan angle was reduced allowing for faster compensation, but you must take care to orient the scanner accurately towards the targets. This new implementation of on-site compensation requires Focus^S and Focus^S Plus scanners, Focus firmware 6.8 (or higher) and SCENE 2021.1 (or higher).

On your Computer

1. In the **Place Targets** page, a picture shows how to place the targets and the scanner for the compensation.
2. If the 6 Target Sheets are not available, click **Open Target PDF** in the toolbar.
3. Select the desired format. The PDF viewer opens, showing the PDF sheet.
4. Print at least 6 marker sheets.

NOTE: We recommend gluing the target sheets on suitably rigid plates, especially if On-Site Compensation is done frequently or outdoors. Make sure the target sheets are firmly attached to the wall and do not move during the scan capture process.

On-Site

Place at least 6 Target sheets on site as follows:

- The target sheets must be placed in a vertical range of -50° to $+50^{\circ}$ from the scanner.

NOTE: Under some circumstances, $+50^{\circ}$ can only be achieved, if the target is placed on the ceiling.

- Distribute the target sheets uniformly throughout the specified range. At least one board must be close to the horizon (0°).
- The distance between the target sheets and the scanner must be between 1.5 m to 3 m.
- All target sheets must be vertically aligned.

Laser Scanner Placement

- Mount the laser scanner on a tripod.
- Place tripod and scanner on a stable, flat surface. The tripod must be immobile during scanning.

Horizontal Alignment

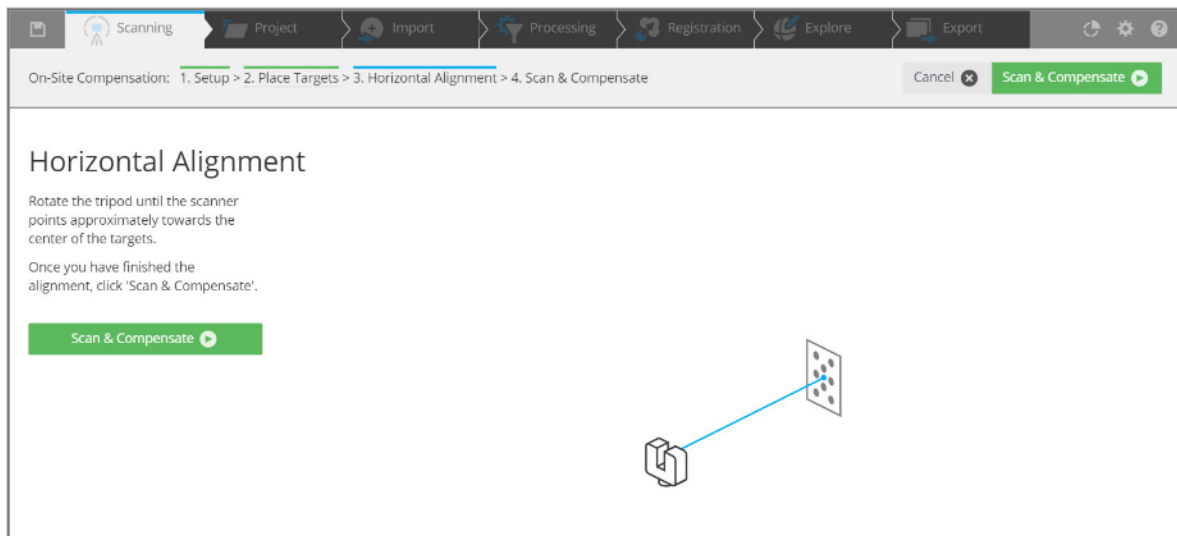

Figure 9-12 Horizontal Alignment

Horizontally align the scanner tripod, rotating the tripod of the scanner to point approximately towards the center of the targets.

Scan & Compensate

- Start scanning and compensating by clicking **Scan & Compensate** from the Horizontal Alignment screen.
- Select whether to apply the compensation data to the scanner.
- Click **disconnect** to disconnect from the scanner, and finish the on-site compensation.
- To apply this compensation to the scanner, click **yes**, then click **Finish**. Click **no**, if to discard the compensation.
- When the compensation is finished, the Compensation Report is displayed with the results of the compensation. Open the compensation report as a PDF file by clicking **Open Report**. The **Compensation Report** is saved as a PDF file to the location specified on the left side of the page.
- During the compensation process, the status of progress is displayed. You can cancel the process, if necessary.

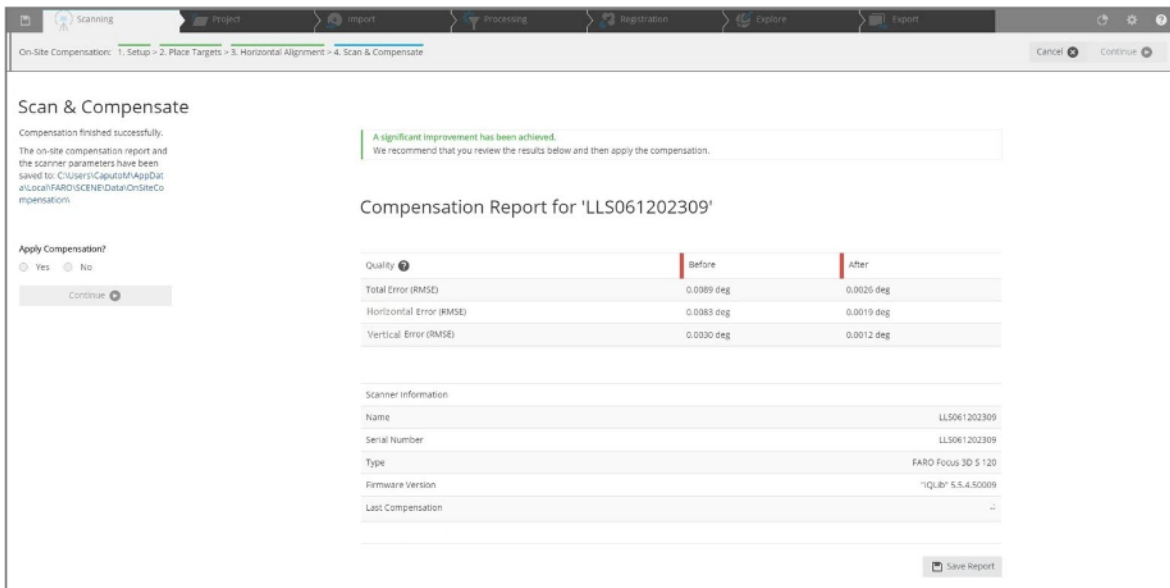

Figure 9-13 Compensation Report

On-Site Compensation Best Practices

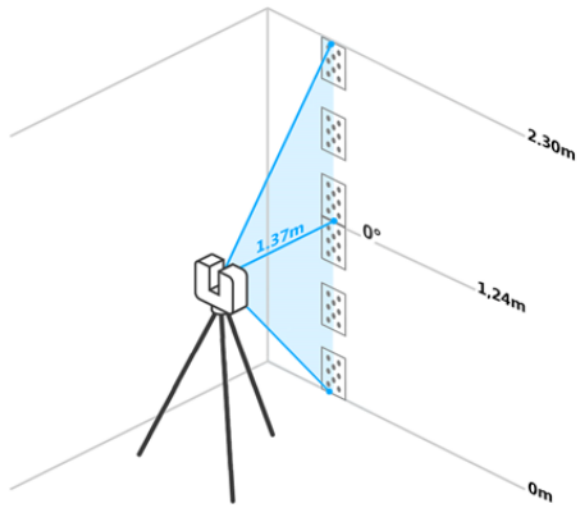

Figure 9-14 Scanner and target arrangement for On-Site Compensation

- Ensure that the target sheets are correctly prepared:
 - Print the targets on standard mat paper (do not use glossy paper).
 - Print the targets with laser printer (do not use an ink jet printer).
 - Glue the target sheets onto suitable, rigid planes.
 - Ensure that the targets are not bent when attached to the wall
- Use a room without moving objects or the presence of other people. Setup the target sheets vertically on planar wall with a ceiling height of about 2.3 m (7.5 ft).
- Place the scanner about 1.37 m (4.5ft) from the wall and extend the first sections (with biggest diameter) on all 3 legs of the tripod. The height of the mirror center will be at about 1.24 m (4 ft).
- Make sure the tripod is placed on a stable, flat surface. The tripod must not move during scanning.
- Make sure the tripod is fully opened and stable and the center column is not extended.
- Level the scanner (check the inclinometer).
- Place the two “center targets” symmetrically at the height of the scanner horizontal axis.
- Place the two “boundary targets” at the bottom and the top of the wall.
- Place the two “middle targets” centered between boundary and center targets.
- All target sheets must be vertically aligned.

Troubleshooting

Reading and writing to the selected data output folder failed.

Solution: Ensure that you have permission to read and write in the selected output folder. Also, ensure that there is sufficient disk space (approximately 330MB).

The process did not identify enough targets for compensation.

Solution: A `targetImage.png` file is stored in the output folder. This image shows the identified markers as blue circles. Areas with a sufficient amount of detected targets have a green background color. In case of an insufficient amount of detected targets, the background color is red.

No consistent solution could be determined.

Solution: Ensure that the tripod and the targets did not moving during the procedure.

The SD card of the scanner could not be accessed.

Solution: Ensure that the SD card is inserted correctly, and that it is not write-protected, as well as that it has sufficient free space (approximately 330MB).

Communication with the scanner failed.

Solution: Ensure that the WLAN connection to the scanner is stable. If this error appears while connecting to the scanner or applying the compensation parameters, repeat the corresponding step.

Scan Groups

A *scan group* is a set of two or more *detail scans* that were taken using the scan group function. The scanner records fixed spatial relationships between all of the scans in the group. These are shown as a group in SCENE.

Use Scan Groups to Reduce Scanning Time

To minimize scanning time, select the lowest resolution that will capture the physical details needed for your scan project. This resolution may not scan registration targets with the detail you need for accurate registration. Rather than using a higher resolution for the entire scan, make a 360° lower-resolution scan first as a scan group (referred to here as the *primary scan*), then make several higher-resolution *detail scans* of the targets visible in the first scan. This reduces the total time needed to scan the area, while still yielding high-quality scans of the targets to ensure that registration is accurate.

About Detail Scans

Detail scans are different from ordinary scans. They contain no high-precision inclinometer and compass data, and are generally useful only in the context of their scan group.

Creating a Scan Group

NOTICE: The primary scan and the detail scans must all be taken from the same scanner position. Ensure that the scanner tripod or other mount is immobile throughout the procedure. If possible, use WLAN and operate the scanner from a remote user interface (See [WLAN on page 88](#)). If you must use the touchscreen, do not tap the screen hard enough to disturb the scanner.

1. Create a scan. (See [Scanning on page 37](#).) When the scan is finished, the screen switches to the Preview Scans page. This scan is the primary scan of the group.
2. Locate a registration target (or other object) to scan at a higher resolution. Use the mouse-wheel (or pinch gestures) to zoom in to the preview image.
3. Click a target to select it. A blue selection rectangle appears. Drag it to adjust the position.

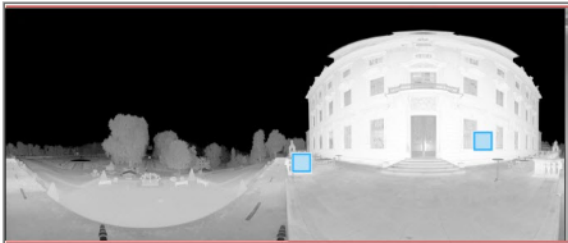

Figure 9-15 Adding detail scans to group

4. Click the selection rectangle to open the detail scan pop-up window.

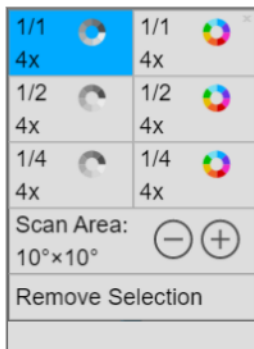

Figure 9-16 Detail scan pop-up

5. Select the resolution, quality, and color type for the detail scan. Change the size of the scan area, or remove the selection, if necessary. Click X in the upper-right corner of the window to dismiss it.
6. Repeat through for each target to be scanned.
7. When you have selected all the targets to be scanned, click **Add Scans to Group**. The scanner begins to make detail scans. The scanner screen shows you the progress.



Figure 9-17 Detail scans completed

When all the detail scans are complete, the preview image of the primary scan is displayed. The positions of the completed detail scans appear as red squares. To make more detail scans, repeat the procedure above. Remember to make all the detail scans needed before moving the scanner or making a new primary scan.



Figure 9-18 Scan group



To see the scan groups on the SD card, return to the scanner's start page and click **Scans**. All scans of a scan group are shown indented below the caption *Scan Group* and the scan group's name (which is always the name of the primary scan).

NOTE: Scan groups are supported by SCENE 2018 and later. If you import scan groups into an older version of SCENE, the detail scans are treated as normal scans, and are thus likely to have limited use for registration.

Retaking Pictures

When making color scans, photographs are used to colorize the points recorded by the laser. If a person, vehicle, or other object moves into the camera's field of vision after scanning, but while pictures are being taken, it can result in scan points with incorrect colors. If you have set the scanner to allow pictures to be

retaken, check the pictures on the scanner immediately after they are taken, select any pictures that include objects that were not part of the laser scan, and retake them.

1. Before scanning, ensure that Retake Pictures is enabled. *For more information, see “General Settings” on page 85.*
2. Begin the scan as usual. When the scan completes, the Color Preview page is displayed.
3. Examine the pictures. If any pictures need to be retaken for any reason, select them by tapping or clicking. If the pictures are fine, close the scan by leaving the Color Preview page.
4. After you have selected all the pictures to be retaken, tap the retake picture button . The scanner retakes and replaces the pictures.
5. If any pictures need to be retaken, repeat the last two steps. Otherwise, close the scan by pressing the finalize scan button .

NOTICE: Risk of data loss:

When the Retake Pictures feature is enabled, the scan is not completed until you exit the Color Preview page. Ensure that the scan is closed and that the SD card symbol in the status bar is not blinking before removing the SD card or switching off the scanner.

NOTE: The scan is not complete until it is closed, and thus no longer visible to other devices, such as while you are retaking pictures. This can affect on-site registration, which begins only after the scan is closed.

Chapter 10: Maintenance

We recommend that you check your FARO Laser Scanner at least once a month. This allows you to spot trouble before it starts, and provides you with an efficient measuring system.

The FARO Laser Scanner is a precision instrument that contains many sensitive components, and thus must be handled with care. Follow these procedures to prevent problems:

- Check the cables for damage to outside insulation, connectors, and pins.
- Check the housing of the scanner for damage.
- Check the housing and the connectors of the battery for damage.
- Place a dust cover over the scanner, when not in use.
- Do not lubricate the FARO Laser Scanner.

To ensure proper functioning of the scanner, it should be checked by FARO customer service on a regular basis within the yearly maintenance and certification service. The service intervals should not exceed one year. Contact your local FARO Customer Service team for more information.

Cleaning Instructions for Optics

Major contamination and improper cleaning of optics and lenses can impact the scanning quality. Major damage or wear might require a complete replacement of the part.

NOTICE: Damage or wear of the scanner's mirrors and lenses: The following must be observed.

- To avoid unnecessary damage or wear, clean the optics only if the degree of contamination requires cleaning for proper functioning. For example, if an increase in noise or a decrease of the scan range is observed. Major contamination can impact the scanning quality. In this case, proper cleaning of the outer optics (rotating mirror module or sensor cover glass) is recommended.
 - Cleaning must be performed only by trained personnel, as self-inflicted damage may result in a complete replacement of the part at the expense of the customer. If in doubt, contact the customer service at FARO (*Technical Support on page 156*).
 - Do not touch the optical surfaces with your bare hands or laboratory gloves. We recommend using latex gloves. If you have latex allergies, use gloves that are suitable for you or have someone else carry-out the cleaning.
 - Lightly rub the gloves with laboratory cloths after removing them. Use isopropyl alcohol to remove grease and dirt.
 - Do not touch the mirror with tweezers or forceps.
 - Use only acetone-free cleaning fluids.
-

What Is Needed

Gather the supplies listed below, before beginning the procedures detailed in this chapter.

1. **Compressed air, non-flammable spray (oil-free)** such as *Techspray DUSTER 1671* (highly recommended by FARO), available from optical supply stores such as:
 - <https://www.techspray.com/duster-7>
 - <https://www.thorlabs.de/thorproduct.cfm?partnumber=CA4-US>
(United States and Canada compliant duster with integrated nozzle)
 - <https://www.thorlabs.de/thorproduct.cfm?partnumber=CA4-EU>
(European Union compliant duster with integrated nozzle)
2. **Acetone-free, non-flammable optics cleaning fluid** such as *Dust-Aid Ultra Clean Liquid* (highly recommended by FARO) , available from optical supply stores such as:
 - <https://dust-aid.com/dslr-camera-sensor-cleaning-liquid/>
(Order via sales@dust-aid.com)
3. **Lens tissue**, available from optical supply stores such as:
 - <https://www.thorlabs.de/thorproduct.cfm?partnumber=MC-5>
4. **Small dropping bottle and medium wash bottles**, available from optical or chemical supply stores such as:
 - <https://www.thorlabs.de/thorproduct.cfm?partnumber=B2939>

5. **Stainless steel forceps**, available from optical or chemical supply stores such as:
 - <https://www.thorlabs.de/thorproduct.cfm?partnumber=FCP>
(Forceps, solid stainless steel)
 - <https://www.thorlabs.de/thorproduct.cfm?partnumber=FCPA>
(Angled Forceps, solid stainless steel)
6. **Powder-free lab gloves** (PVC or silicone), available from optical or chemical supply stores.
7. For strongly contaminated optics, **Mild neutral soap**, available from optical or chemical supply stores.

Cleaning Slightly Contaminated Optics

WARNING: Hand injuries

If the scanner is accidentally switched on, the mirrors may start to turn. Before starting any cleaning activity:

- shut-down the laser scanner module and remove the battery pack.
- if using an external power supply, remove the power line.

This will prevent the mirror from turning during the cleaning.

Dry Pre-Cleaning (Non-Contact Cleaning)

Start removal of dust or liquid droplet contamination on mirror or sensor cover by using compressed dry air or special duster sprays (dry cleaning gas).

NOTICE: Do not shake the Duster Spray bottle.

While using the duster spray, ensure that you do not shake the bottle or turn it upside down.



Figure 10-1 Dry pre-cleaning with compressed air or duster cleaning spray

NOTICE: Damage of the scanner's mirrors and lenses

Avoid any direct contact with the optical surface.

1. Gently blow off particles from the optical surface with compressed air.
2. Perform visual inspection.
3. Repeat dry cleaning as required.
4. Proceed with *Wet Cleaning with Tissue and Isopropyl Alcohol as a Cleaning Fluid* below.

Wet Cleaning with Tissue and Isopropyl Alcohol as a Cleaning Fluid

NOTICE: Damage of the scanner's mirrors and lenses

Use a new pair of gloves for the following steps.

Prepare the Cleaning Pad



Figure 10-2 Assemble the cleaning pad

1. Combine 2 or 3 sheets of optics cleaning tissue.

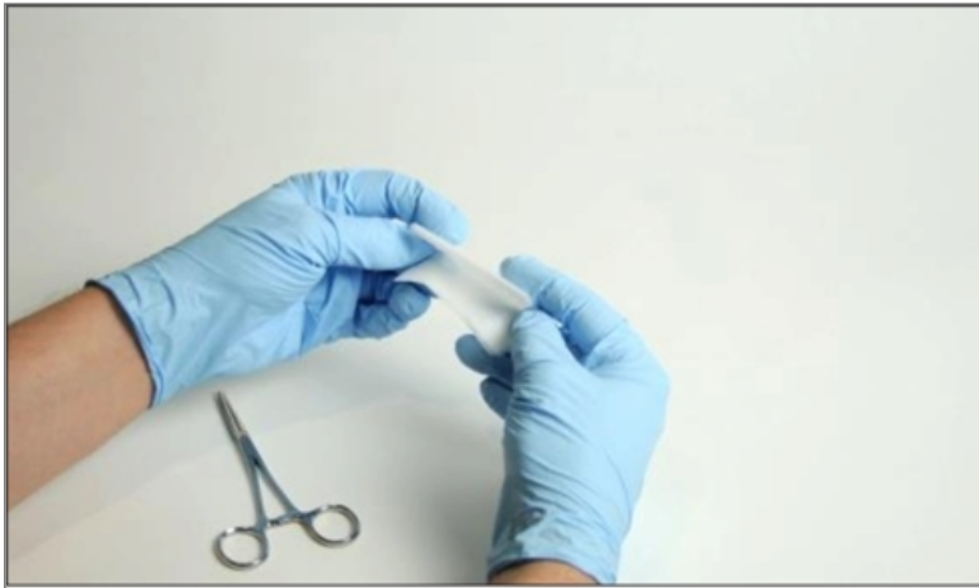

Figure 10-3 Folding the cleaning pad (1)



Figure 10-4 Folding the cleaning pad (2)

2. Repeatedly fold the cleaning pads in half, as shown above. Fold twice on the long side, then turn 90° and fold twice more to create a soft pad that is about 30 mm long.

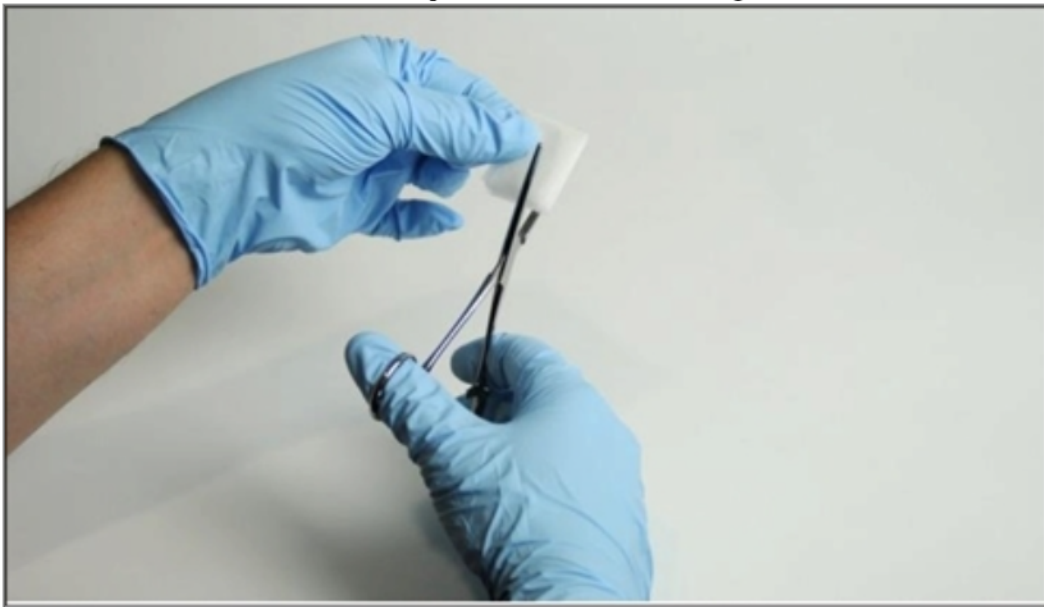

Figure 10-5 Fix the cleaning pad

3. Use the forceps to fix the cleaning pad, as shown above. Leave at least 2-3 mm between the edge of the pad and the forceps.

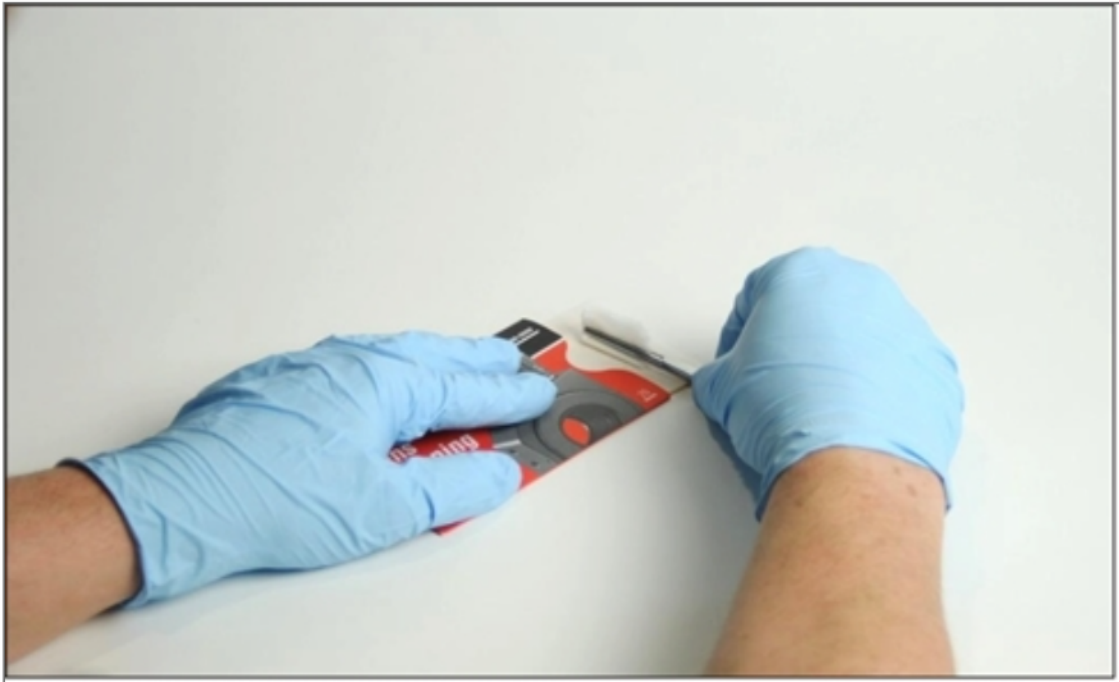

Figure 10-6 Creating a T-shaped cleaning pad (1)



Figure 10-7 Creating a T-shaped cleaning pad (2)

4. Slightly compress the pad on top of the spare cleaning tissues to create a T-shaped cleaning pad, as shown above.



Figure 10-8 Soaking the cleaning pad

5. Use the eye-dropper to soak the cleaning pad with isopropyl alcohol or cleaning fluid, as shown above.

Cleaning mirror module or sensor cover



ass="Caption_Figure_Left" MadCap:autonum="Figure 1-7 ">Cleaning mirror module with pad and isopropyl alcohol or cleaning fluid

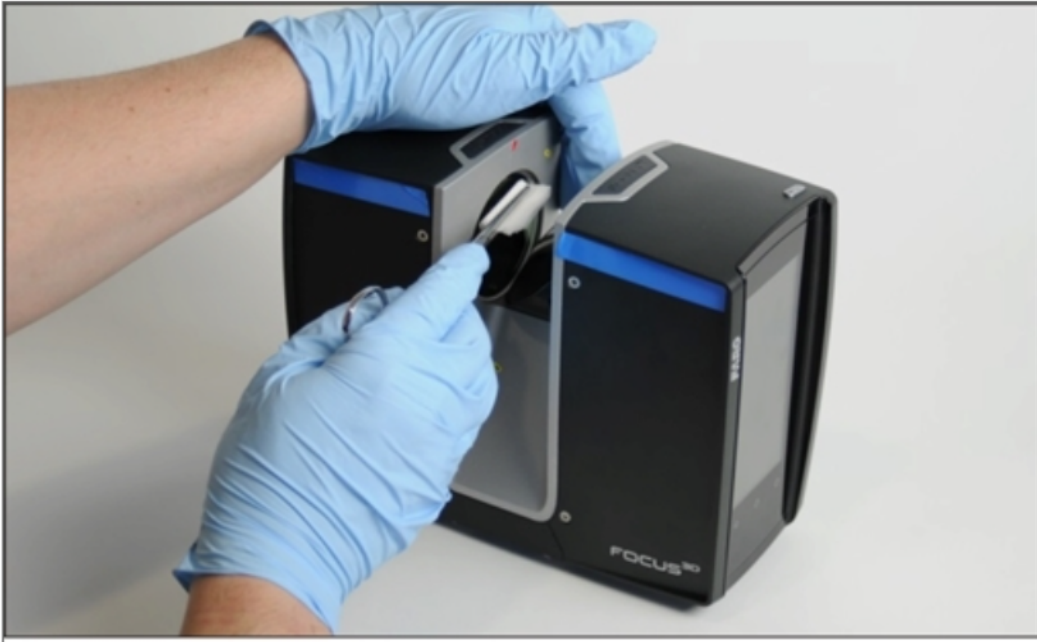

Figure 10-9 Cleaning sensor cover with pad and isopropyl alcohol or cleaning fluid

NOTICE: Damage of the scanner's mirrors and lenses

Avoid any contamination of the cleaning tissue.

Do not apply pressure while wiping. This might damage the optical surface.

1. With a single, consistent linear motion from one end to the other, gently wipe the mirror or sensor cover glass with the cleaning pad, as shown above.
2. After each cleaning cycle, discard the cleaning pad and prepare a new pad as described under [Prepare the Cleaning Pad on page 137](#).
3. Repeat the cleaning until the full mirror or sensor cover aperture has been wiped once.
4. Check cleaning status by visual inspection.
5. Prepare another cleaning pad with isopropyl alcohol or optics cleaning fluid to finalize the procedure.
6. Gently wipe the mirror's entire surface with gentle pressure and in a linear direction once through.
7. Check cleaning status by visual inspection. Ensure that no contamination remains. If there is still contamination, repeat the cleaning with isopropyl alcohol or optics cleaning fluid.

Cleaning of Strongly Contaminated Optics

WARNING: Hand injuries

If the scanner is accidentally switched on, the mirrors may start to turn. Before starting any cleaning activity:

- shut-down the laser scanner module and remove the battery pack.
- if using an external power supply, remove the power line.

This will prevent the mirror from turning during the cleaning.

Dry Pre-Cleaning (Non-Contact Cleaning)

Always start removal of dust or liquid droplet contamination on mirror or sensor cover by using compressed dry air or special duster sprays (dry cleaning gas).

NOTICE: Do not shake the Duster Spray bottle.

While using the duster spray, ensure that you do not shake the bottle or turn it upside down.



Figure 10-10 Dry pre-cleaning by compressed air or duster cleaning spray

NOTICE: Damage of the scanner's mirrors and lenses

Avoid any direct contact with the optical surface.

1. Gently blow off particles from the optical surface with compressed air.
2. Perform visual inspection.
3. Repeat dry cleaning as required.
4. Proceed with *Wet Cleaning with Water or Diluted Mild Soap Solution* below.

Wet Cleaning with Water or Diluted Mild Soap Solution

Provide a rigid base, for example, table or transport box topside, as a stable base for the following cleaning procedure:

1. Remove laser scanner unit from its tripod.



Figure 10-11 Transport box with laser scanner turned and laid on top, with the mirror module facing outwards

2. Lay the scanner on its long side.

3. Ensure that the mirror can move freely, and is easily accessible for wet cleaning.

NOTICE: Damage of the scanner's mirrors and lenses

Use dust-free gloves for the following steps.

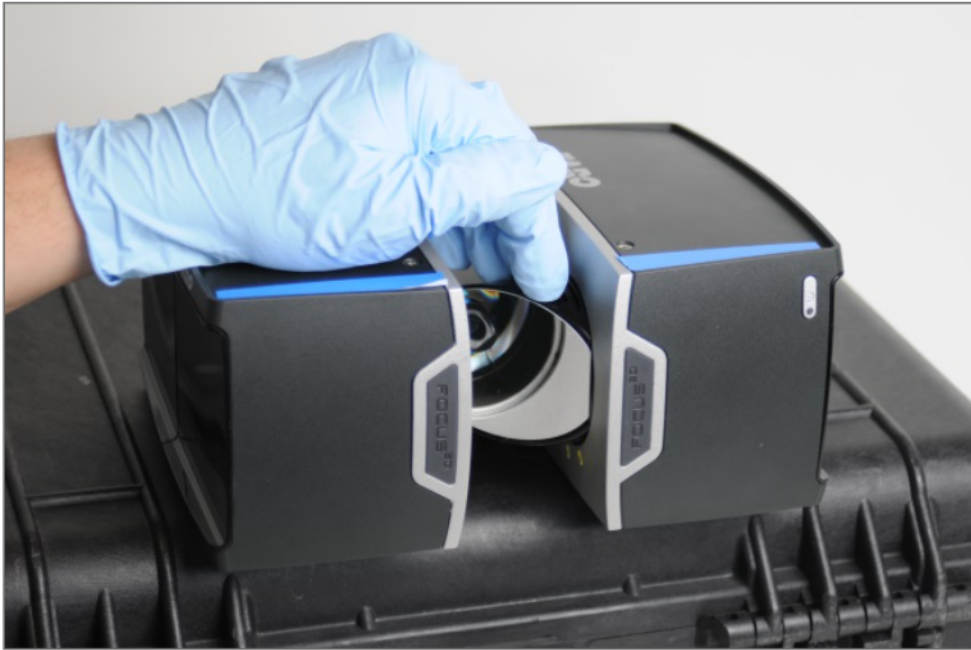

Figure 10-12 Fix the mirror with your finger tips to keep it in this position

4. Turn the mirror module into a vertical position, i.e., the mirror points away from scanner. Secure the mirror with your finger tips to keep it in this position.



Figure 10-13 Cleaning mirror module or sensor cover

5. Clean the mirror module (analogue: sensor cover) by rinsing with water or diluted neutral soap solution in oscillation motion.

NOTICE: Damage of the scanner's mirrors and lenses

Wait for the cleaning liquid to drain or dry off. Do not try to dry the optics by wiping with tissue at this stage, because residual contamination may cause severe damage to optics.

1. Perform visual inspection of cleaning status.
2. Repeat the rinsing step until contamination is significantly reduced or removed.
3. Wait for the optics to dry.
4. Turn laser scanner into upright (normal) position and ensure stable placement. For example, place scanner on a table or transport box. Alternatively, use tripod for mounting.
5. Proceed with *Wet Cleaning with Tissue and Isopropyl Alcohol as a Cleaning Fluid* on page 136.

Chapter 11: Technical Data

General

| | |
|---|---|
| Power supply voltage: | 19 V (external supply) 14.4 V (internal battery) |
| Power consumption: | 15 W (when device is idle) 25 W (while scanning) 80 W (while battery charges) |
| Battery life (average): | 4.5 hours |
| Operating temperature: | 5 °C to 40 °C |
| Cable connector: | Located under the battery cover. |
| Weight: | 4.2 kg |
| Size: | 240 x 200 x 100 mm |
| Recommended maintenance / calibration: | Annual |

Laser (Optical Transmitter)

Laser class:



| | |
|------------------------|--------------------------------|
| Wavelength: | 1550 nm |
| Beam divergence: | Typical 0.3 mrad (0.024°)(1/e) |
| Beam diameter at exit: | Typical 2.12 mm (1/e) |

Data Handling and Control

| | |
|------------------|--|
| Data storage: | SD cards of type SDHC™ and SDXC™; 32 GB card included |
| Scanner control: | Touchscreen display and WLAN connection. Access by mobile devices using HTML5. |

Ranging Unit

Focus^S Plus

| | |
|---|---|
| Distance Accuracy: | 1 mm |
| Angular Accuracy: | Horizontal: 19 arcsec Vertical: 19 arcsec |
| Unambiguity interval: | 614 m for up to 0.5 Mio. pts/s; 307 m at 1 Mio. pts/s; 153 m at 2 Mio. pts/s |
| Range Focus ^S Plus 150: | 0.6 m to 150 m indoor or outdoor with upright incidence to a 10% reflective surface |
| Range Focus ^S Plus 350: | 0.6 m to 350 m indoor or outdoor with upright incidence to a 10% reflective surface |
| Measurement speed (pts/sec): | up to two million |
| Ranging error ¹ Focus ^S : | ±1 mm |

| Ranging noise ² | @10 m | @25 m |
|----------------------------|--------|--------|
| @ 90% refl. | 0.1 mm | 0.2 mm |
| @ 10% refl. | 0.3 mm | 0.5 mm |

Focus^S

| | |
|---|---|
| Distance Accuracy: | 1 mm |
| Angular Accuracy: | Horizontal: 19 arcsec Vertical: 19 arcsec |
| Unambiguity interval: | 614 m for up to 0.5 Mio. pts/s; 307 m at 1 Mio. pts/s; |
| Range FocusS 70: | 0.6 m to 70 m indoor or outdoor with upright incidence to a 10% reflective surface |
| Range FocusS 150: | 0.6 m to 150 m indoor or outdoor with upright incidence to a 10% reflective surface |
| Range FocusS 350: | 0.6 m to 350 m indoor or outdoor with upright incidence to a 10% reflective surface |
| Measurement speed (pts/sec): | up to one million |
| Ranging error ¹ Focus ^S : | ±1 mm |

| Ranging noise ² | @10 m | @25 m |
|----------------------------|--------|--------|
| @ 90% refl. | 0.3 mm | 0.3 mm |
| @ 10% refl. | 0.4 mm | 0.5 mm |

Focus^M

| | |
|---------------------------------------|--|
| Unambiguity interval: | 614 m for up to 0.5 Mio. pts/s; |
| Range FocusM 70: | 0.6 m to 70 m indoor or outdoor with upright incidence to a 10% reflective surface |
| Ranging error ¹ FocusM 70: | ±3 mm |
| Measurement speed (pts/sec): | up to 0.5 Million |

Color Unit

| | |
|-------------|---------------------------|
| Resolution: | Up to 165 megapixel color |
| HDR: | 2x, 3x, 5x |
| Parallax: | Co-axial design |

Multi-Sensor

| | |
|------------------------|---|
| Dual axis compensator: | Levels each scan: 19 arcsec; Range ±2° |
| Height sensor: | Via an electronic barometer the height relative to a fixed point can be detected and added to a scan. |
| Compass ³ : | The electronic compass gives the scan an orientation. |
| GPS: | Integrated GPS receiver |

Interface Connection

WLAN: 802.11n (150 Mbit/s)
Ad-hoc and Infrastructure mode

Deflection Unit

| | |
|---------------------------|--|
| Field of view: | (vertical/horizontal): 300° ⁴ / 360° |
| Step size: | (vertical/horizontal): 0.009° (40,960 3D-Pixel on 360°) / 0.009° (40,960 3D-Pixel on 360°) |
| Max. vertical scan speed: | 5,820 rpm or 97 Hz |

Ambient Conditions

| | |
|---------------------------------|--|
| Ambient Temperature: | 5 °C to 40 °C |
| Extended operating temperature: | -20 to 55°C Low temperature operation: the scanner must be powered on while internal temperature is at or above 15 °C High temperature operation: additional accessory required, further information on request. |
| Humidity: | Non-condensing |
| Altitude: | < 2000 m |

Notes

¹ Ranging error is defined as a systematic measurement error at around 10 m and 25 m, one sigma.

² Ranging noise is defined as a standard deviation of values about the best-fit plane for measurement speed of 122,000 points/sec.

³ Ferromagnetic objects and electromagnetic fields can disturb the earth magnetic field. This, as well as local variations in earth magnetic field (magnetic declination or variation), can lead to inaccurate measurements.

⁴ 2x150° - Homogeneous point spacing is not guaranteed.

Scanner Dimensions

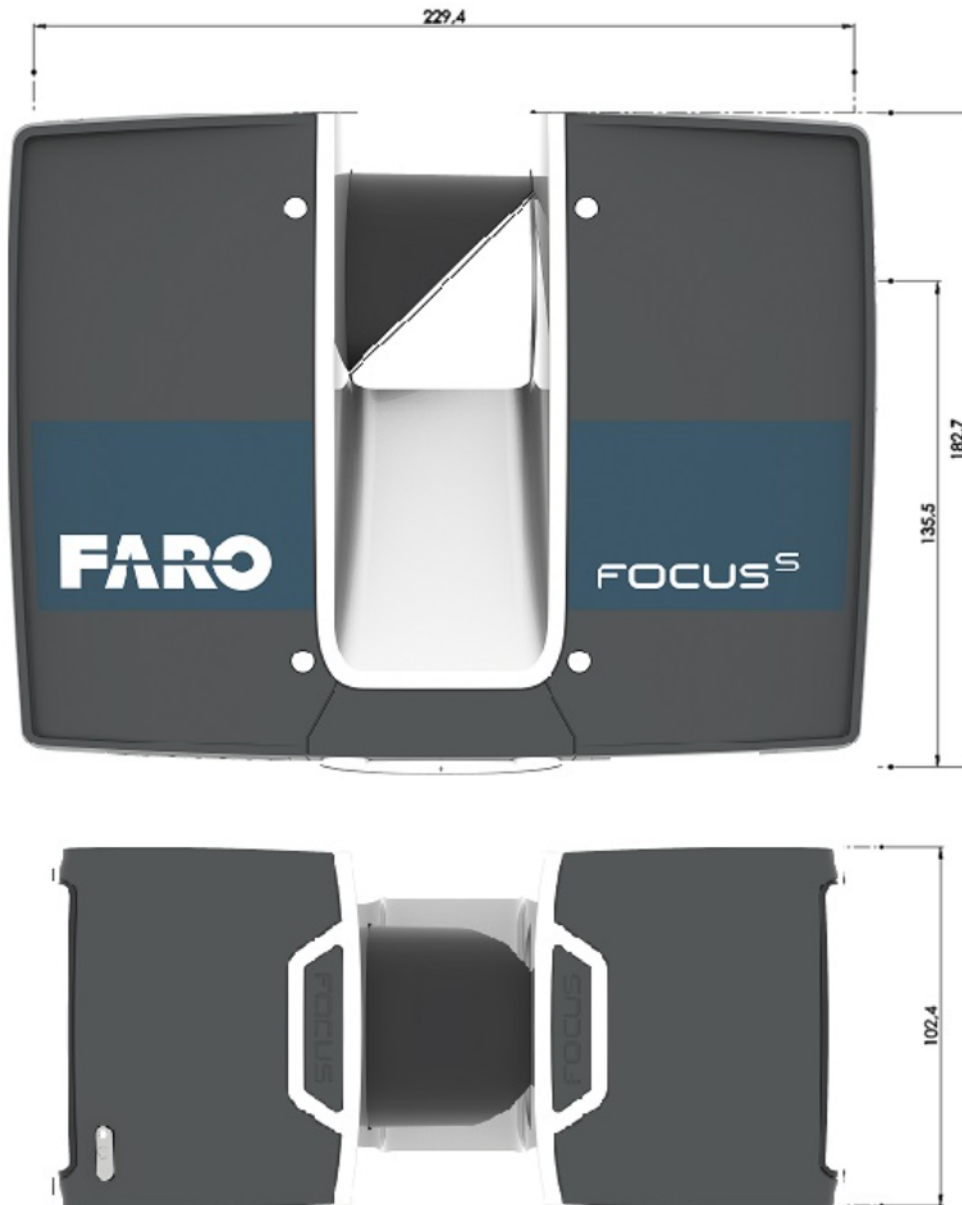

Figure 11-1 Scanner Dimensions

All dimensions are in mm.

Scanner Mount Dimensions

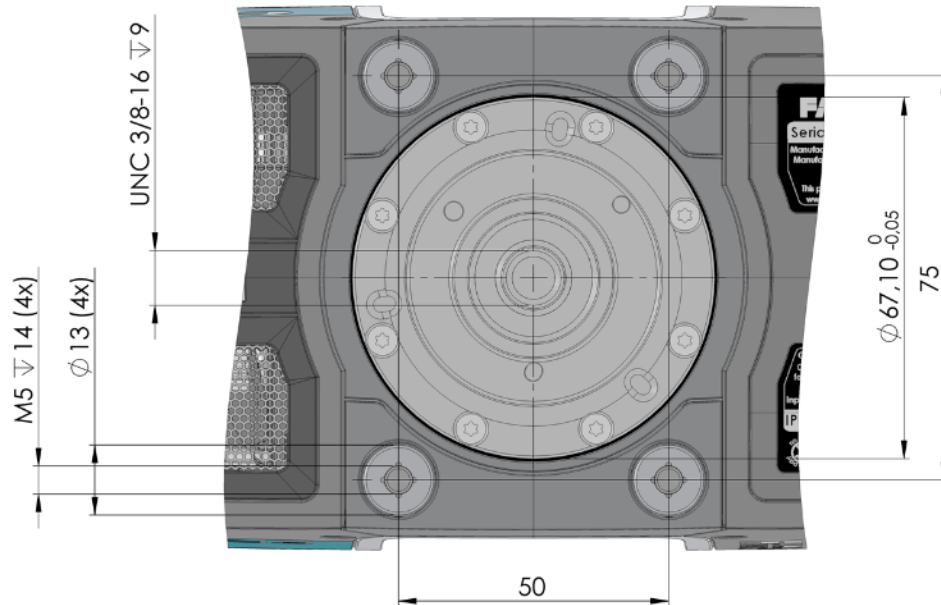

Figure 11-2 Scanner mount

The 3/8 inch central thread can be used to mount a fixation device below the scanner.

The scanner has 4 M5 tapped holes as interface for helical operation.

All dimensions are in mm.

Chapter 12: Error Messages

| Error Message | Description | Action |
|---|--|---|
| Internal Error: Invalid parameter | Inconsistent scanner parameters. | Restart scanner. If the problem still occurs, contact FARO Customer Service. |
| Distance measurement tolerance exceeded | The white reference area on the scanner's base gave inconsistent measurements. | Check cleanliness of this reference area, mirror, and lenses. |
| error | The device could not be found. | Restart scanner. If the problem still occurs, contact FARO Customer Service. |
| Color acquisition failure | Color acquisition has unexpectedly stopped. Color acquisition probably incomplete. | Save log file and contact FARO Customer Service. |
| Out of time failure | Indicates an internal scanner error. | Restart scanner. If the problem still occurs after restart, contact FARO Customer Service. |
| Module Status Error | Module Status Error: Data version mismatch. | Internal scanner communication problem. Contact FARO Customer Service for a firmware upgrade. |
| Scanner Operation Failure | Internal scanner error. | Restart scanner. If the problem still occurs, contact FARO Customer Service. |
| Command not executed | Command could not be executed because of a previous running scan operation. A scan is still active, you cannot start the next operation now. | Wait until scanning is finished. |
| Scanner temperature too low | Scanner's temperature is too low. Scanning is not possible. | Warm up the scanner before further use. |
| Temperature too high | Scanner's temperature is too high. Scanning is not possible. | Shut down the scanner and let it cool down, or check if the fan is running. If the fan is not running, enable fan |

| Error Message | Description | Action |
|--|--|---|
| | | cooling under Manage - Sensors - Temperature . |
| Internal memory full | Internal scanner hard drive is full. | Free-up space by deleting wallpapers, operators, projects, or profiles. If that does not help, contact FARO customer service. |
| Possible file system corruption on SD card detected. Do you want the scanner to repair the file system on the SD card? | The scanner has detected file system corruptions on the inserted SD card. Damages to the file system may occur when you remove the SD card from your computer without using the option <i>Safely Remove Hardware</i> in Microsoft Windows. | Let the scanner repair the SD card. Note that repairing might delete erroneous files from the SD card. If you see this error message again, you should consider replacing the SD card. To prevent damage to the file system when removing the SD card, always use <i>Safely Remove Hardware</i> in Microsoft Windows. |
| Warning | Permanent warning error. If an empty or full SD card is inserted, the LED turns red and a permanent notification is displayed. However, when the SD card is removed, both warnings remain active until the scanner is shut down. | Restart scanner. If the problem still occurs, contact FARO Customer Service. |
| Unknown error | An unknown error occurred. | Restart scanner. If the problem still occurs, contact FARO Customer Service. |

Chapter 13: Disposal

At the end of its life-cycle, this product must not be disposed with normal waste, but instead must be returned to a recycling facility for electric and electronic devices.

Contact your local government or local waste disposal operators to ensure you comply with local laws.



Chapter 14: Technical Support

FARO Technologies, Inc. is committed to providing the best technical support to our customers. Our Service Policy is detailed under *Industrial Service Policy* on page 166 this manual. If you have any difficulties using one of our products, follow these steps before contacting our Technical Support Team:

- Be sure to read the relevant sections of the documentation.
- Visit the FARO Customer Care area on the Web at www.faro.com to search our technical support database. This is available 24 hours a day 7 days a week.
- Document the problem you are experiencing. Be as specific as you can. The more information you can give us, the easier the issue is to solve.
- If you still cannot resolve your issue, have your device's serial number available before calling.
- Emails or faxes sent outside regular working hours are usually answered before 12:00 noon the next working day. If our staff are on other calls, leave a voice mail. Calls are always returned within 24 hours on business days. Remember to leave a detailed description of your difficulty along with your device's serial number. Do not forget to include your name, fax number, and telephone number with extension, so we can promptly reach you.

| | |
|---------------|---|
| North America | Support Hours (Monday through Friday) |
| | 8:00 a.m. to 7:00 p.m. Eastern Standard Time (EST) |
| | Email: support@faro.com |
| | Phone: +1 800 736 2771, +1 407 333 3182 (Worldwide) |
| | Mexico: 866-874-1154 |
| Europe | Fax: +1 407-562-5294 |
| | Support Hours (Monday through Friday) |
| | 8:00 a.m. to 5:00 p.m. Central European Standard Time (CET) |
| | Email: support.emea@faro.com |
| | Phone: +800 3276 7378, +49 7150 9797 400 (Worldwide) |
| Asia | Fax: +800 3276 1737, +49 7150 9797 9400 (Worldwide) |
| | Support Hours (Monday through Friday) |

8:30 a.m. to 5:30 p.m. Singapore Standard Time (SST)

Email: supportap@faro.com

Phone: +1 800 511 1360, +65 6511 1350 (Worldwide)

Fax: +65 6543 0111

Support Hours (Monday through Friday)

9:00 a.m. to 5:00 p.m. Japan Standard Time (JST)

Japan

Email: supportjapan@faro.com

Phone: +81 561 63 1411 (Worldwide)

Fax: +81 561 63 1412

Support Hours (Monday through Friday)

8:30 a.m. to 5:30 p.m. China Standard Time (CST)

China

Email: supportchina@faro.com

Phone: +400.677.6826

Fax: +86 21 6494 8670

Support Hours (Monday through Friday)

9:30 a.m. to 5:30 p.m. India Standard Time (IST)

India

Email: supportindia@faro.com

Phone: 1800.1028456

Fax: +91 11.4646.5660

Appendix A: Software License Agreement

This Software License Agreement is part of the Operating Manual for the product and software system for which you have purchased from FARO Technologies Inc. (collectively, the “Licensor”). With your use of the software, you are agreeing to the terms and conditions of this Software License Agreement. Throughout this Software License Agreement, the term “Licensee” means the owner of the System.

I. The Licensor hereby grants the Licensee the non-exclusive right to use the computer software described in this Operating Manual (the “software”). The Licensee shall have no right to sell, assign, sub-license, rent or lease the software to any third party without the Licensor’s prior written consent.

II. The Licensor further grants the Licensee the right to make a backup copy of the software media. The Licensee agrees that it will not decompile, disassemble, reverse engineer, copy, transfer, or otherwise use the software except as permitted by this section. The Licensee further agrees not to copy any written materials accompanying the software.

III. The Licensee is licensed to use the Software only in the manner described in the Operating Manual. Use of the Software in a manner other than that described in the Operating Manual or use of the software in conjunction with any non-Licensor product which decompiles or recompiles the software or in any other way modifies the structure, sequence or function of the software code, is not an authorized use, and further, such use voids the Licensor’s set forth below.

IV. The only warranty with respect to the software and the accompanying written materials is the warranty, if any, set forth in the Quotation/Purchase Order and [Purchase Conditions on page 160](#) pursuant to which the software was purchased from the Licensor.

V. THIS WARRANTY IS IN LIEU OF OTHER WARRANTIES, EXPRESS OR IMPLIED, INCLUDING, BUT NOT LIMITED TO, THE IMPLIED WARRANTIES OF MERCHANTABILITY AND FITNESS FOR A PARTICULAR PURPOSE WITH RESPECT TO THE SOFTWARE AND WRITTEN MATERIALS. IN NO EVENT WILL THE LICENSOR BE LIABLE FOR DAMAGES, INCLUDING ANY LOST PROFITS OR OTHER INCIDENTAL OR CONSEQUENTIAL DAMAGES ARISING OUT OF THE USE OR INABILITY TO USE THE SOFTWARE, NOTWITHSTANDING THAT THE LICENSOR HAVE BEEN ADVISED OF THE POSSIBILITY OF SUCH DAMAGES, THE LICENSOR WILL NOT BE LIABLE FOR ANY SUCH CLAIM BY ANY OTHER PARTY.

VI. In the event of any breach by the Licensee of this Agreement, the license granted hereby shall immediately terminate and the Licensee shall return the software media and all written materials, together with any copy of such media or materials, and the Licensee shall keep no copies of such items.

VII. The interpretation of this Agreement shall be governed by the following provisions:

A. This Agreement shall be construed pursuant to and governed by the substantive laws of the State of Florida (and any provision of Florida law shall not apply if the law of a state or jurisdiction other than Florida would otherwise apply).

B. If any provision of this Agreement is determined by a court of competent jurisdiction to be void and non-enforceable, such determination shall not affect any other provision of this Agreement, and the

remaining provisions of this Agreement shall remain in full force and effect. If any provision or term of this Agreement is susceptible to two or more constructions or interpretations, one or more of which would render the provision or term void or non-enforceable, the parties agree that a construction or interpretation which renders the term of provision valid shall be favored.

C. This Agreement constitutes the entire Agreement, and supersedes all prior agreements and understandings, oral and written, among the parties to this Agreement with respect to the subject matter hereof.

VIII. If a party engages the services of an attorney or any other third party or in any way initiates legal action to enforce its rights under this Agreement, the prevailing party shall be entitled to recover all reasonable costs and expenses (including reasonable attorney's fees before trial and in appellate proceedings).

Appendix B: Purchase Conditions

All Purchase Orders (hereafter, the “Order”) for FARO-provided products and services (hereafter, the “Product”) are subject to the following terms and conditions, which are agreed to by the Purchaser. All capitalized terms are defined in Section [8.00 Definitions](#) on page 164 hereafter.

1.00 Payment of Purchase Price

1.01 Purchaser hereby promises to pay to the order of FARO all deferred portions of the Purchase Price, together with interest on late purchase price payments payable at 1.5% per month (18% per annum).

1.02 The Purchaser grants to FARO a security interest in the products sold pursuant to the Order, which may be perfected by UCC-1 Financing Statements to be recorded in the applicable County of the Purchaser’s business location and filed with the Secretary of State’s Office, which security interest will remain in effect until payment in full of the purchase price together with interest on late purchase price payments payable thereon had been received by FARO.

1.03 If the Purchaser fails to make full payment of the purchase price within the period set out in the Order, FARO shall at its option have the following remedies, which shall be cumulative and not alternative:

- a) the right to cancel the Order and enter the Purchaser’s premises to re-take possession of the Product, in which event the Purchaser agrees that any down-payment or deposit shall be forfeited to FARO, as liquidated damages and not as a penalty, and all costs incurred by FARO in connection with the removal and subsequent transportation of the Product shall be payable by the Purchaser upon written demand;
- b) the right to enter the Purchaser’s premises and remove any Software, components of the Product or other items necessary in order to render the Product inoperative;
- c) the right to withhold all services which would otherwise be required to be provided by FARO pursuant to the Warranties set out in Section [4.00 Warranties and Limitation of Liability](#) on the next page hereof;
- d) terminate any existing software license agreement and
- e) pursue any other available remedy, including suing to collect any remaining balance of the purchase price (i.e., accelerate the payment of the purchase price causing the entire balance to immediately become due and payable in full).
- f) Customer will be charged a 20% restocking fee for refusal to accept equipment as delivered. Equipment must be returned unopened within 10 business days of receipt at customer facility.

1.04 If Purchaser fails to make payment(s) in accordance with the terms of this Order, the Purchaser’s Products may be rendered inoperable until such payment terms are met.

No waiver by FARO of its rights under these conditions shall be deemed to constitute a waiver of subsequent breaches or defaults by the Purchaser. In the event more than one Product is being purchased pursuant to the Order, unless otherwise set forth herein, each payment received by FARO from Purchaser shall be applied pro rata against the cost of each product rather than being applied to the purchase price of any product.

2.00 Delivery and Transportation

2.01 Delivery dates are estimates and not guarantees, and are based upon conditions at the time such estimate is given.

2.02 FARO shall not be liable for any loss or damage, whether direct, indirect or consequential, resulting from late delivery of the Product. The Purchaser's sole remedy, if the Product is not delivered within 90 days of the estimated delivery date, shall be to cancel the Order and to recover from FARO without interest or penalty, the amount of the down-payment or deposit and any other part of the purchase price which has been paid by the Purchaser. Notwithstanding the foregoing, such right of cancellation shall not extend to situations where late delivery is occasioned by causes beyond FARO's control, including, without limitation, compliance with any rules, regulations, orders or instructions of any federal, state, county, municipal or other government or any department or agency thereof, force majeure, acts or omissions of the Purchaser, acts of civil or military authorities, embargoes, war or insurrection, labor interruption through strike or walkout, transportation delays and other inability resulting from causes beyond FARO's control to obtain necessary labor, manufacturing facilities or materials from its usual sources. Any delays resulting from such causes shall extend estimated delivery dates by the length of such delay.

2.03 Responsibility for all costs and risks in any way connected with the storage, transportation, and installation of the Product shall be borne entirely by the Purchaser. If any disagreement arises as to whether or not damage to the Product was in fact caused in storage, transit or on installation, the opinion of FARO's technical advisors, acting reasonably, shall be conclusive.

3.00 Installation and Operator Training

3.01 The Purchaser shall be responsible for installation of the Product, including, without limitation, the preparation of its premises, the uncrating of the Product and setting up of the Product for operation. Purchaser may elect to order contract services from FARO to perform this service should they elect to do so.

4.00 Warranties and Limitation of Liability

4.01 FARO warrants that (subject to Section 4.06), the Product shall be free from defects in workmanship or material affecting the fitness of the Product for its usual purpose under normal conditions of use, service, and maintenance. A complete statement of FARO's maintenance/warranty service is set forth in [Purchase Conditions on the previous page](#).

4.02 FARO warrants that the Software shall operate according to specifications and the System shall operate and perform in the manner contemplated in connection with the usual purpose for which it is designed.

4.03 The maintenance/warranty set out in paragraphs 4.01 shall expire at the end of the twelve (12) month period commencing on the date of shipment from the FARO factory (the "Maintenance/Warranty Period").

4.04 Subject to the limitations contained in Section 4.06, the Warranties shall apply to any defects found by the Purchaser in the operation of the FARO Laser Scanner and reported to FARO within the Maintenance/Warranty Period. If the FARO Laser Scanner or the Software is found by FARO, acting reasonably, to be defective, and if the defect is acknowledged by FARO to be the result of FARO's faulty material or workmanship, the FARO Laser Scanner will be repaired or adjusted to the extent found by

FARO to be necessary or at the option of FARO, replaced with a new FARO Laser Scanner or parts thereof at no cost to the Purchaser.

4.05 Claims under the Warranties shall be made by delivering written notice to FARO of the defect in the System, the FARO Laser Scanner. Within a reasonable time of receipt of such notice, FARO shall have the System and FARO Laser Scanner diagnosed by its service personnel, and maintenance/warranty service will be provided at no cost to the Purchaser if the System and FARO Laser Scanner is found by FARO to be defective within the meaning of this Section.

(If, in the reasonable opinion of FARO after diagnosis of the system and the FARO Laser Scanner are not defective, the Purchaser shall pay the cost of service, which shall be the amount that FARO would otherwise charge for an evaluation under a non-warranty service evaluation.

4.06 The Warranties do not apply to:

- a) Any defects in any component of a System where, if in the reasonable opinion of FARO, the FARO Laser Scanner, Software or System has been improperly stored, installed, operated, or maintained, or if Purchaser has permitted unauthorized modifications, additions, adjustments, and/or repair to any hard drive structure or content, or any other part of the System, or which might affect the System, or defects caused or repairs required as a result of causes external to FARO workmanship or the materials used by FARO. As used herein, “unauthorized” means that which has not been approved and permitted by FARO.
- b) The Warranties shall not cover replacement of expendable items, including, but not limited to, fuses, diskettes, printer paper, printer ink, printing heads, disk cleaning materials, or similar items.
- c) The Warranties shall not cover minor preventive and corrective maintenance, including, but not limited to, replacement of fuses, disk drive head cleaning, fan filter cleaning and system clock battery replacement.
- d) Any equipment or its components which was sold or transferred to any party other than the original Purchaser without the expressed written consent of FARO.

4.07 Factory Repairs

- a) IF SYSTEM IS UNDER MAINTANENCE/WARRANTY: The Purchaser agrees to ship the Product to FARO in the original packing containers. FARO will return the repaired or replacement Product. FARO will incur the expense of the needed part and all return shipping charges to the Purchaser. FARO may authorize the manufacturer of a component of the Product to perform the service.
- b) IF SYSTEM IS UNDER PREMIUM SERVICE PLAN: When practical and subject to availability, FARO will make available to the Purchaser substitute component parts or FARO Laser Scanner’s (“Temporary Replacements”) while corresponding parts of the Purchaser’s system or FARO Laser Scanner are undergoing repair at FARO’s factory. Shipping charges for these “Temporary Replacement” parts or FARO Laser Scanner’s will be the responsibility of FARO.
- c) IF SYSTEM IS NOT UNDER MAINTANENCE/WARRANTY: The Purchaser is responsible for the cost of the replacement part or software, and all shipping charges. All charges shall be estimated and prepaid prior to commencement of repairs.
- d) Replacement parts used for repair may be new, refurbished, or contain refurbished materials.

4.08 Nothing herein contained shall be construed as obligating FARO to make service, parts, or repairs for any product available after the expiration of the Maintenance/Warranty Period.

4.09 Limitation of Liability

FARO shall not be responsible under any circumstances for special, incidental or consequential damages, including, but not limited to, injury to or death of any operator or other person, damage or loss resulting from inability to use the System, increased operating costs, loss of production, loss of anticipated profits, damage to property, or other special, incidental or consequential damages of any nature arising from any cause whatsoever whether based in contract, tort (including negligence), or any other theory of law. FARO's only liability hereunder, arising from any cause whatsoever, whether based in contract, tort (including negligence) or any other theory of law, consists of the obligation to repair or replace defective components in the System or FARO Laser Scanner subject to the limitations set out above in this section.

This disclaimer of liability for consequential damage extends to any such special, incidental or consequential damages which may be suffered by third parties, either caused directly or indirectly resulting from test results or data produced by the system or any component thereof and the Purchaser agrees to indemnify and save FARO harmless from any such claims made by third parties.

4.10 The foregoing shall be FARO's sole and exclusive liability and the Purchaser's sole and exclusive remedy with respect to the system.

THE SOLE RESPONSIBILITY OF FARO UNDER THE WARRANTIES IS STATED HEREIN AND FARO SHALL NOT BE LIABLE FOR CONSEQUENTIAL, INDIRECT, OR INCIDENTAL DAMAGES, WHETHER THE CLAIM IS FOR BREACH OF WARRANTY, NEGLIGENCE, OR OTHERWISE.

OTHER THAN THE EXPRESS WARRANTIES HEREIN STATED, FARO DISCLAIMS ALL WARRANTIES INCLUDING IMPLIED WARRANTIES OF MERCHANTABILITY AND FITNESS.

4.11 FARO does not authorize any person (whether natural or corporate) to assume for FARO any liability in connection with or with respect to the Products. No agent or employee of FARO has any authority to make any representation or promise on behalf of FARO, except as expressly set forth herein, or to modify the terms or limitations of the Warranties. Verbal statements are not binding upon FARO.

4.12 The Maintenance/Warranties extend only to the Purchaser and are transferable, only under the following conditions:

- The FARO Laser Scanner is currently under maintenance/warranty.
- New owner is, or becomes, a certified user.
- A FARO maintenance/warranty transfer form is completed, and submitted to Customer Service.

All claims under the Warranties must originate with the Purchaser, or any subsequent owner, and the Purchaser will indemnify and save FARO harmless from any claims for breach of warranty asserted against FARO by any third party.

4.13 Oral representations of FARO or its sales representatives, officers, employees or agents cannot be relied upon as correctly stating the representations of FARO in connection with the system. Refer to this purchase order, any exhibits hereto and any written materials supplied by FARO for correct representations.

4.14 PURCHASER ACKNOWLEDGES THAT IT HAS PURCHASED THE SYSTEM BASED UPON ITS OWN KNOWLEDGE OF THE USES TO WHICH THE SYSTEM WILL BE PUT. FARO SPECIFICALLY DISCLAIMS ANY WARRANTY OR LIABILITY RELATED TO THE FITNESS OF THE SYSTEM FOR ANY PARTICULAR PURPOSE OR ARISING FROM THE INABILITY OF THE PURCHASER TO USE THE SYSTEM FOR ANY PARTICULAR PURPOSE.

5.00 Design Changes

5.01 The FARO Laser Scanner, the Software and the System are subject to changes in design, manufacture, and programming between the date of order and the actual delivery date. FARO reserves the right to implement such changes without the Purchaser's consent, however, nothing contained herein shall be construed as obligating FARO to include such changes in the FARO Laser Scanner, Software or System provided to the Purchaser.

6.00 Non-Disclosure

6.01 All Software including, without limitation, the Operating System Program and any FARO special user programs, provided to the Purchaser as part of the system, either at the time of or subsequent to the delivery of the FARO Laser Scanner, is the intellectual property of FARO. The Purchaser shall not reproduce or duplicate, disassemble, decompile, reverse engineer, sell, transfer or assign, in any manner the Software or permit access to or use thereof by any third party. The Purchaser shall forthwith execute any further assurances in the form of non-disclosure or licensing agreements which may reasonably be required by FARO in connection with the software.

7.00 Entire Agreement / Governing Law / Miscellaneous / Guarantee

7.01 These Purchase conditions constitute the entire agreement between FARO and the Purchaser in respect to the Product. There are no representations or warranties by FARO, express or implied, except for those herein contained and these conditions supersede and replace any prior agreements between FARO and the Purchaser.

7.02 No representative of FARO has any authority to modify, alter, delete or add to any of the terms or conditions hereof. Any such modifications shall be absolutely void unless made by instrument in writing properly executed by an actual authorized employee or agent of FARO.

7.03 The terms and conditions hereof shall be binding upon FARO and the Purchaser, and shall be construed in accordance with the laws of the State of Florida, United States of America.

7.04 FARO shall be entitled to recover all of its reasonable fees and costs including, but not limited to, its reasonable attorney's fees incurred by FARO in connection with any dispute or litigation arising thereunder or in connection herewith, including appeals and bankruptcy or creditor reorganization proceeds.

7.05 These conditions shall not be construed more strictly against one party than another as a result of one party having drafted said instrument.

8.00 Definitions

8.01 "FARO" means FARO Technologies Inc..

8.02 "Purchaser" means the party buying the Product and who is legally obligated hereunder.

8.03 "Software" means all computer programs, disk drive directory organization and content, including the computer media containing such computer programs and disk drive directory organization and content, sold pursuant to the Order.

8.04 "Product" means the FARO Laser Scanner, the Software, operating manuals and any other product or merchandise sold pursuant to the Order. If the Purchaser is buying only a FARO Laser Scanner, or the Software, Product will mean the product being purchased by the Purchaser pursuant to the Order.

8.05 "System" means a combination of the FARO Laser Scanner, the Software, the Computer, and optional parts and accessories associated with the FARO Laser Scanner.

8.06 "Purchase Order" means the original document issued from the Purchaser to FARO, listing all parts and/or services to be purchased and the agreed purchase price.

8.07 “Maintenance/Warranty Transfer Form” means a document to be completed for the transfer of the FARO Maintenance/Warranty. This document is available from FARO upon request.

Appendix C: Industrial Service Policy

This Service Plan (hereafter, the “Plan”) is part of the Operating Manual for the FARO manufactured product purchased from FARO Technologies Inc. (hereafter, “FARO”). The Plan and all of the optional additions, are subject to the conditions in Appendices A, B, & C, and are subject to change. This appendix refers to FARO’s service plans as written in the sales advertising literature, and is meant to provide additional details that the literature does not permit.

1.00 The purchase of the Plan shall occur with the purchase of the FARO products.

1.01 The plan shall apply to systems exclusively created or authored by FARO.

1.02 The plan shall include FARO product hardware only, and can not be extended or transferred through the sale of any part of the system to a third party unless the entire system has been sold or transferred.

1.03 The plan shall not cover Hardware or Software which has been subjected to misuse or intentional damage. FARO reserves the right to determine the condition of all returned Hardware and/or Software.

1.04 FARO shall determine the service method and contractor to service/repair all hardware which is not directly manufactured by FARO. All outside contractor terms and conditions are available from FARO and are incorporated herein by reference.

1.05 FARO shall not be responsible for any non-FARO authored software which inhibits the operation of the system. Furthermore the plan will not cover the re-installation of any software.

1.06 The Hardware and Software are subject to changes in design, manufacture, and programming. All updates are as follows:

- a) Hardware - The FocusS150 and all of the associated optional parts, and the Computer are not subject to updates.
- b) Software - All computer programs, authored by FARO, which are used in conjunction with the FARO provided Hardware, will be updated (maintenance upgrades) for the life of the Purchaser’s current version. All enhancement and functionality upgrades must be purchased.
- c) 3rd Party Software - All computer programs not authored by FARO will not be updated under the Plan. The purchaser is responsible for the acquisition of all 3rd party software updates and warranty service or claims.

1.07 In the event that FARO replaces any product or replacement product, FARO retains all right, title, and interest in and to all products or portions of products that were replaced by FARO.

2.00 Definitions

2.01 “FARO” means FARO Technologies Inc..

2.02 “Purchaser” means the party buying the Product and who is legally obligated hereunder.

2.03 “Software” means all computer programs, disk drive directory organization and content, including the diskettes containing such computer programs and disk drive directory organization and content, sold pursuant to the Order.

2.04 “Product” means the FARO® Laser Scanner FocusS 150, the Software, operating manuals and any other product or merchandise sold pursuant to the Order. If the Purchaser is buying only a FARO® Laser Scanner FocusS 150, or the Software, Product will mean the product being purchased by the Purchaser pursuant to the Order.

2.05 “System” means a combination of the Hardware, the Software, the Computer, and optional parts associated with the FARO® Laser Scanner FocusS 150.

2.06 “Hardware” means the scanner and all of the associated optional parts, and the Computer if provided by FARO.

2.07 “Software” means all computer programs, authored by FARO, which are used in conjunction with the FARO provided Hardware.

The following is a layman’s definition of the coverage.

Standard Service Plans

All shipping times below are to destinations within the Continental United States. Outside the Continental U.S., FARO will ship equipment directly to the customs broker.

- Standard Service Plans are contracted at time of purchase or at any time while a unit is covered by a FARO hardware service plan (as described in more detail later).
- The Standard Service Plan covers the FARO® Laser Scanner FocusS 150 and controller box.
- Shipping costs, including insurance from the Purchaser to FARO are the responsibility of the Purchaser. FARO will be responsible for all return shipping costs including insurance.
- All reasonable efforts will be made to keep the service repair time within 7 (FaroArm) or 14 (Laser Tracker and Laser Scanner) working days. The equipment will be returned via 2-Day air service, therefore, total service repair time will vary due to return shipping location.
- Since the FocusS150 is designed to be used with many other software packages not authored by FARO, this service plan can be purchased in its entirety to cover only FARO produced or authored products. For items not produced or authored by FARO, the customer is responsible for securing their own separate warranty or service plan coverage.

Hardware Coverage

FARO SCENE Covered

- All parts and labor for FARO® Laser Scanner FocusS 150s failing under normal use as described in Appendix B.
- Annual calibration and re-certification of the FARO® Laser Scanner FocusS 150.

Not Covered

- Misuse
- Intentional damage
- Wear and tear of probes, ball bars, auxiliary hardware products such as cables, wrenches, hex keys, screwdrivers, etc.

Computer Covered

- FARO contracts with 3rd party service providers for this service for up to 3 years. The terms and conditions of FARO's contract with the provider apply herein and are incorporated herein by reference.
- Typically, these services include repair of the computer, memory cards, and video monitors.

Not Covered

- All exclusions contained in the 3rd party service providers policy which is incorporated herein by reference.
- Software operating system installation.
- User intentional or unintentional removal of key software property or files.

Software Coverage

Covered

- Periodically, FARO Technologies Inc. may release maintenance updates of its proprietary software. This will be supported through the life of the product version. All enhancement and functionality upgrades will be available in the next full version for a fee.

Not Covered

- End users are responsible for the procurement and installation of 3rd party authored or S/W updates as required to use with FARO authored software products, unless FARO Technologies resold these packages to the end user as an authorized reseller. Examples of 3rd party authored S/W are: DOS, Windows, AutoCAD, AutoSurf, SurfCAM, and others.

Premium Service Plans

The Premium Service Plans additionally provide loaner FARO® Laser Scanner FocusS 150s and Computers when service is required. All equipment shipping costs are paid for by FARO (both ways). FARO will make its best effort to ship all loaner FocusS150s within 24 hours of the receipt of the purchasers request. Once the need for a service has been verified by FARO, FARO will make its best effort to ship all loaner computers within 72 hours of the receipt of the purchaser's request.

Appendix D: Industrial Products Service Policy

A one-year maintenance/warranty comes with the purchase of new FARO manufactured hardware products.

The most regular of the FARO Standard Maintenance Terms and Conditions can be found in the FARO Knowledge base.

FARO Software

All FARO Software users will receive maintenance releases until the end of life for the version at no charge electronically or at a minimal fee for the computer media package. All enhancement and functionality upgrades will be available for purchase upon release.

Hardware & Software Training

FARO's training program is designed to instruct trainees in the operation of FARO's hardware and software, which the customer has purchased. The training classes are set up for each trainee to obtain valuable hands on application exposure. This will help the trainees in their everyday use of the hardware and software. FARO also feels that once the trainee completes the training, finding solutions to problems or applying applications will be simpler.

Appendix E: Certifications

FCC Notice

FCC Equipment Authorization

Trade name: FARO

Product Name: Focus

These devices comply with Part 15 of the FCC Rules

Operation is subject to the following conditions:

1. The devices may not cause harmful interference, and
2. The devices must accept any interference received, including interference that may cause undesired operation.

Contains FCC ID: PV7-WIBEAR11N-SF1

NOTE: This equipment has been tested and found to comply with the limits for a Class A digital device, pursuant to part 15 of the FCC Rules. These limits are designed to provide reasonable protection against harmful interference when the equipment is operated in a commercial environment. This equipment generates, uses, and can radiate radio frequency energy and, if not installed and used in accordance with the instruction manual, may cause harmful interference to radio communications. Operation of this equipment in a residential area is not likely to cause harmful interference

Industry Canada (IC):

This device complies with Industry Canada license-exempt RSS standard(s). Operation is subject to the following two conditions:

- (1) This device may not cause interference.

(2) This device must accept any interference, including interference that may cause undesired operation of the device.

Le présent appareil est conforme aux CNR d'Industrie Canada applicables aux appareils radio exempts de licence. L'exploitation est autorisée aux deux conditions suivantes:

- (1) l'appareil ne doit pas produire de brouillage, et
- (2) l'utilisateur de l'appareil doit accepter tout brouillage radioélectrique subi, même si le brouillage est susceptible d'en compromettre le fonctionnement.

Contains IC ID: 7738A-WB11NSF1

CE Conformity

DocuSign Envelope ID: A6F4F9A2-BE61-47E1-A0D5-2D6BE3B4B063



EN

EC Declaration of Conformity



The manufacturer,

FARO Europe GmbH
Lingwiesenstraße 11/2
Korntal-Münchingen, 70825
Germany

**Name and address of the person
authorised to compile the technical file:**

FARO Europe GmbH
Lingwiesenstraße 11/2
Korntal-Münchingen, 70825
Germany

Declares under his sole responsibility that the product:

Generic Designation, Type and Function: Laser Scanner
Model: Focus M 70, Focus S 70, Focus S 150, Focus S 350
Focus S 70 A, Focus S 150 A, Focus S 350 A
Focus S Plus 150, Focus S Plus 350
Focus S Plus 150 A, Focus S Plus 350 A
Serial Number: LLS081609000 - LLS082122000

Is in conformity with the relevant Community harmonisation legislation:

EU Directives
2006/42/EC - Machinery
2014/53/EU - RED
2011/65/EU - RoHS

Standards
EN 50581:2012
EN 60825-1:2014
EN 61010-1:2010
EN 61326-1:2013
EN 62311:2008
ETSI EN 300 328 V2.1.1
ETSI EN 301 489-1 V2.2.1
ETSI EN 301 893 V2.1.1
ETSI EN 303 413 V1.1.1

Korntal-Münchingen, 08.06.2021

DocuSigned by:

ESCAFA46EAF3482
Benjamin Welker
Managing Director

FARO Technologies, Inc.

250 Technology Park
Lake Mary, FL 32746
800-736-2771 U.S. / +1 407-333-3182 Worldwide
Email: support@faro.com

FARO Brazil

Rua San José, 360
Cotia, SP 06715-862
Phone: 0800-047-4271 / +55 11 3500-4600
Email: suporte@faro.com

FARO Europe GmbH & Co. KG

Lingwiesenstrasse 11/2 D-70825
Korntal-Münchingen, Germany
FREECALL +800 3276 73 78 / +49 7150/9797-400
FREEFAX +800 3276 1737 / +49 7150/9797-9400
Email: support.emea@faro.com

FARO Singapore Pte. Ltd.

No. 03 Changi South Street 2
#01-01 Xilin Districentre Building B
SINGAPORE 486548
TEL: +65 6511.1350
Email: supportap@faro.com

FARO Japan,c.

716 Kumada, Nagakute-City,
Aichi, 480-1144, Japan
Tel: 0120-922-927, 0561-63-1411
FAX:0561-63-1412
Email: supportjapan@faro.com

FARO (Shanghai) Co., Ltd.

1/F, Building No. 2,
Jux Information Technology Park
188 Pingfu Road, Xuhui District
Shanghai 200231, China
Tel.: 400.677.6826
Email: supportchina@faro.com

FARO Business Technologies India Pvt. Ltd.

E-12, B-1 Extension,
Mohan Cooperative Industria Estate,
New Delhi-110044, India
Tel.: 1800.1028456
Email: supportindia@faro.com